

L.E.S. Series VW Packaged Boilers

30 to 100 psi Water Shock-Proof Vertical Design Unrestricted HWR/HWS Differential 83% Efficiency Structural Steel Skids

RATINGS // DATA // DIMENSIONS

Model: VW-	25*	37	50*	60	70*	78	100*	110	135*	150	180*	200	220*	245	270*	315	340*	375	
Input																			
Gas (MB/CF) CFH	200	305	399	505	600	700	900	1000	1200	1350	1635	1800	2000	2200	2420	2825	3020	3300	
Oil (140MB/Gal) GPH	1.4	2.2	2.9	3.6	4.3	5.0	6.4	7.1	8.6	9.6	11.7	12.9	14.3	15.7	17.3	20.2	21.6	23.6	
Output																			
MBH	165	250	330	420	500	575	750	835	1000	1125	1360	1500	1675	1840	2010	2345	2510	2750	
Boiler Horsepower	5.0	7.5	10.0	12.5	15.0	17.5	22.5	25.0	30.0	33.5	40.7	44.8	50.0	55.0	60.0	70.0	75.0	82.5	
Gas Burner Motor HP	.25	.25	.25	.25	.25	.25	.33	.33	.33	.33	.33	.33	.5	.5	1.0	1.0	1.0	2.0	
Oil Burner Motor HP	.25	.25	.25	.33	.33	.33	.33	.33	.5	.5	.75	.75	.75	.75	1.5	1.5	1.5	2.0	
Sq.Ft. Heating Surface																			
Primary	7.9	7.8	11.1	10.9	12.9	12.8	15.2	16.0	17.3	18.2	19.9	22.1	23.2	25.6	26.5	29.1	29.4	32.3	
Total Fireside	24	33	45	53	61	70	90	98	121	136	162	180	199	222	244	282	307	338	
Total Waterside	26	36	50	58	66	77	99	108	133	150	179	200	220	246	271	313	340	375	
Boiler Data																			
Furnace Vol. (Cu.Ft.)	1.9	1.9	3.3	3.3	4.3	4.3	5.6	6.1	7.2	7.8	9.1	10.7	11.7	13.8	14.7	17.3	17.6	20.6	
Water Cap. (Gal; Full)	41	38	59	57	78	75	98	92	128	119	153	136	190	169	240	209	272	240	
Dry Weight (LBS)	500	550	775	825	975	1025	1225	1275	1500	1575	1825	1925	2150	2275	2550	2775	3150	3350	
Dimensions in Inches																			
A Skid Length	30		36		36		39		43		45		50		54		57		
AA Overall Length	48		51		54		56		62		64		72		78		88		
B Width	22		25		28		30¼		34¼		36½		41		45		49		
C Height	53		64		66		71		71		77		78		78		78		
F Flue Conn. Size	5		6		6		8		8		10		10		12		12		
G Gas Conn. Size ¹	¾		¾	1	1		1		1¼		1½		2		2		2		
P Burner Port Height	12		13		14		16		16		16		17		17		17		
Burner Port ID	5		5	6½	9¼		9¼		9¼		9¼		9¼		9¼		9¼	14¼	
R Return Size ²	1½		1½		1½		1½		2		2½		3		3		3		
Return Height	7		7		7		7		7		7		8		8		8		
Height with Pump	26		26		28		28		30		30		32		38		38		
S Supply Size ²	1½		1½		1½		1½		2		2½		3		3		3		
Supply Height	48		59		60		66		65		72		73		73		73		
Height with C.V.	54		65		66		72		71		78		82		82		82		

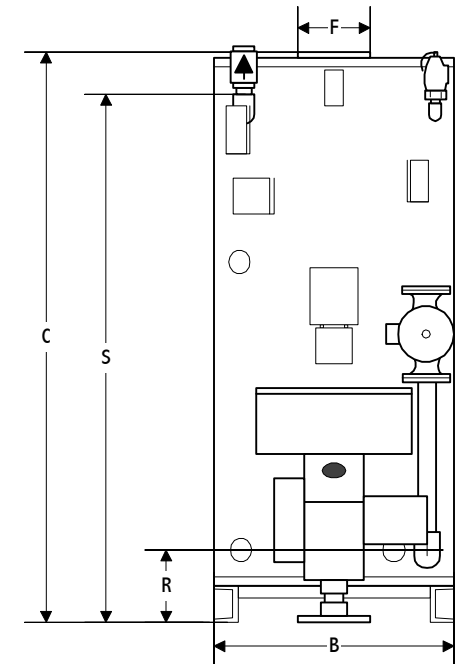
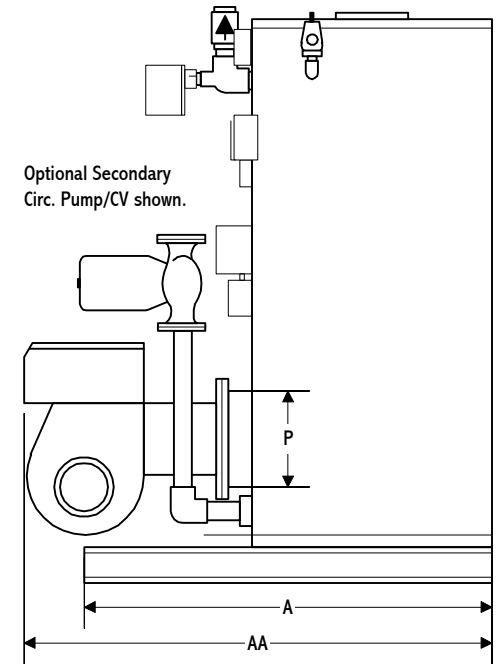

* Full or partial output integral heat exchangers available for these models only. Consult your L.E.S. representative for heat exchanger information.

¹ 7-14" W.C. available. ² Standard inlet/outlet tapings. Consult factory for high flow &/or low delta applications.

PLEASE NOTE: Burner equipment may extend beyond boiler dimensions. See burner dimensional data sheet.