



Industrial/Commercial Division  
Fulton Heating Solutions, Inc.

## Product Data Submittal

Fulton Model: VTG-3000

# Fulton VANTAGE Commercial/Industrial Hydronic Heating Boilers

(Standard Burner)

## Dimensions

A. Boiler Width	IN	34.5
	MM	877
B. Boiler Height w/ Blower	IN	83.9
	MM	2131
C. Boiler Depth w/ Blower	IN	120
	MM	3048
D. Boiler Height w/o Blower	IN	76.25
	MM	1937
E. Flue Outlet Diameter	IN	12
	MM	305
F. Air Inlet Diameter	IN	10
	MM	254
G. To Center of Flue Outlet	IN	18.1
	MM	459.8
H. To Center of Return Water Inlet	IN	35.25
	MM	895.4
I. Water Inlet/Outlet Diameter	IN	4
	MM	102
J. Min. Clearance to Ceiling	IN	24
	MM	610
K. Min. Clearance to either Side Wall (See Note 1)	IN	12
	MM	458
Min. Clearance to Front	IN	36
	MM	915
Min. Clearance to Rear	IN	24
	MM	610

L. Condensate Drain Diameter	IN	1
	MM	25.4
M. Water Outlet from Front of Skid	IN	38.5
	MM	978
N. Water Outlet from Side	IN	14.25
	MM	362
O. To Center of Air Inlet	IN	75.25
	MM	1912
P. Water Inlet from Side	IN	6
	MM	152.4

Specifications and Dimensions are approximate and for reference only.  
We reserve the right to change specifications and/or dimensions.

**NOTE:**

1. Consult factory for 1" side clearance.

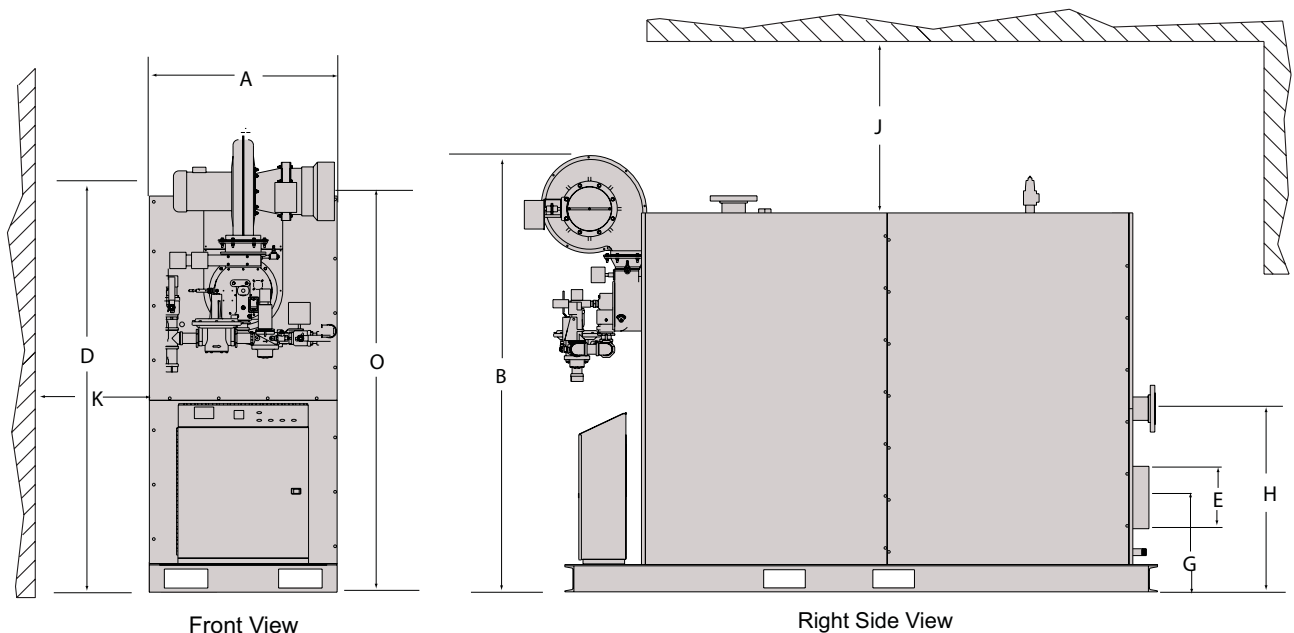
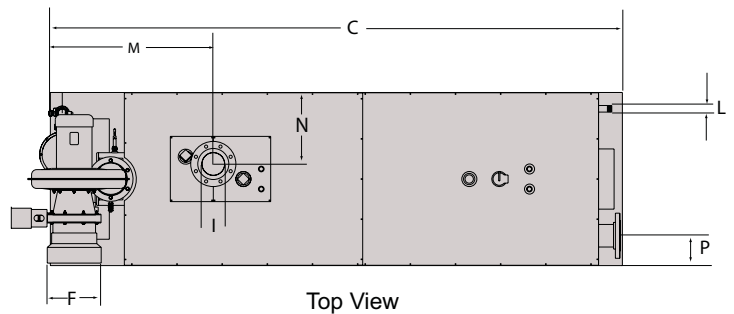

# Specifications

972 Centerville Road  
 Pulaski, New York USA 13142  
 Call 315-298-5121  
 Fax 315-298-6390  
 web site: www.fulton.com

**Industrial/Commercial Division**  
**Fulton Heating Solutions, Inc.**

<b>Model</b>	<b>VTG-3000</b>	
Fuel	Nat. Gas or LP <b>See Note 1</b>	
Input	BTU/Hr. KCAL/Hr.	3,000,000 755,988
Output	BTU/Hr. 120°F in—140°F out KCAL/Hr. 49°C in— 60°C out	2,640,000 665,269
Fuel Consumption @ rated capacity:		
Natural Gas	FT3/Hr. M3/Hr.	3000 85
Propane	FT3/Hr. M3/Hr.	1190 33.7
Unit Size/Output	BHP KW	77 774
Electrical Requirements	Amps 230V,60Hz,3 Phase 460V,60Hz,3 Phase	12.9 6.5
MAWP	PSI BAR	160 11.0
Water Content	Gal Liters	215 818
<b>Boiler Connection Sizes</b>		
Safety Valve Inlet	IN MM	1.25 31.8
Safety Valve Outlet	IN MM	1.5 38.1
Water Inlet & Outlet	IN MM	4 104
Air Inlet	IN MM	10 254
Gas Inlet	IN MM	1.5 38.1
Exhaust Outlet	IN MM	12 304
<b>Approximate Weights</b>		
Dry Weight	LB KG	5,200 2,363
Shipping Weight	LB KG	5,700 2,590
Operating Weight	LB KG	7,000 3,181
Floor Loading	LB/FT2 KG/M2	260 1,235

**NOTES:**

1. The turndown ratio is 5:1.

**Air Intake Supply & Exhaust Vent Piping+**

	No. of Feet of Standard Dia. Pipe	No. of 90° Elbows
Min. length air intake supply piping	0	0
Max. length air intake supply piping	35 (10.7m)	4
Min. length exhaust vent piping	0	0
Max. length exhaust vent piping	35 (10.7m)	4

+Screened Termination Couplings inapplicable. Air intake and vent sizes may vary based on the installation. Please contact Fulton for vent sizing assistance. Consult factory for longer air intake and exhaust run requirements.

**Installation Notes**

- Natural Gas Pressure Required: 14" W.C., consult factory for lower gas pressure applications. Minimum Propane Gas Pressure Required: 17" wc.
- One condensate drain can be used for up to 4 boilers. The condensate drain requires a fresh water connection. The connection is a 1/4" compression fitting and the water pressure shall be less than 100 PSI.

