



Pulse

HW

Fully Condensing Hot Water Boilers

300,000 to 2,000,000 Btu/hr



- Efficiencies up to 99%
- Low electrical consumption
- Modulation with a 5:1 turndown
- No minimum flow rate or return water temperature
- No power burner combined with the Pulse design, results in the lowest maintenance cost in the industry.

Another solution from

 **Fulton**[®]

a few of the FEATURES

Fulton Pulse boilers utilize state-of-the-art technology to achieve full modulation. The result is a boiler that offers up to a 5:1 turndown for precise load matching capability.

Highest efficiencies imaginable with Pulse

The Pulse process transfers more heat per square inch than conventional processes, making it the most efficient way of burning fuel. When the boiler's set point is less than 140°F, the boiler will produce condensation which extracts latent heat from the flue gases, producing extremely high efficiencies – up to 99%. In addition, the blower motor turns off during operation, dramatically lowering the electrical usage. The end result is the highest seasonal efficiency available.

- Efficiencies up to 99%
- Low electrical consumption
- Modulation with a 5:1 turndown
- No minimum flow rate or return water temperature
- No power burner combined with the Pulse design, results in the lowest maintenance cost in the industry.
- Small footprint allows installation in multiple buildings or in isolated areas of large plants; fits through standard door openings.



NOTE: Propane fired boilers operate with a turndown ratio of 3:1

Take a

CLOSER LOOK

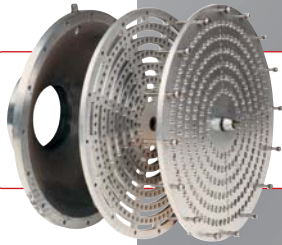

Air & gas flappers act as check valves; allowing flow into the combustion chamber. This patented design is the heart of the Pulse combustion process.



The spark plug allows for direct ignition with low maintenance requirements.



The purge fan operates for pre and post purge only. Once the main flame is established, the fan turns off and the Pulse process naturally draws in the correct amount of air. This results in an extremely low level of electrical consumption.

The air intake & exhaust outlet are both set up and rated for direct vent/sealed combustion. The Pulse combustion design also results in the smallest vent size per BTU as compared to conventional power burners.

The positive pressure produced by Pulse combustion closes both intake metering valves and forces the hot gases out the tail pipes in the to exhaust chamber. The exhaust chamber is constructed from sound deadening material to help reduce noise emissions.

Vibration absorption blocks (standard with all boilers) assist in the reduction of vibration.

1

2

3

4

5

6

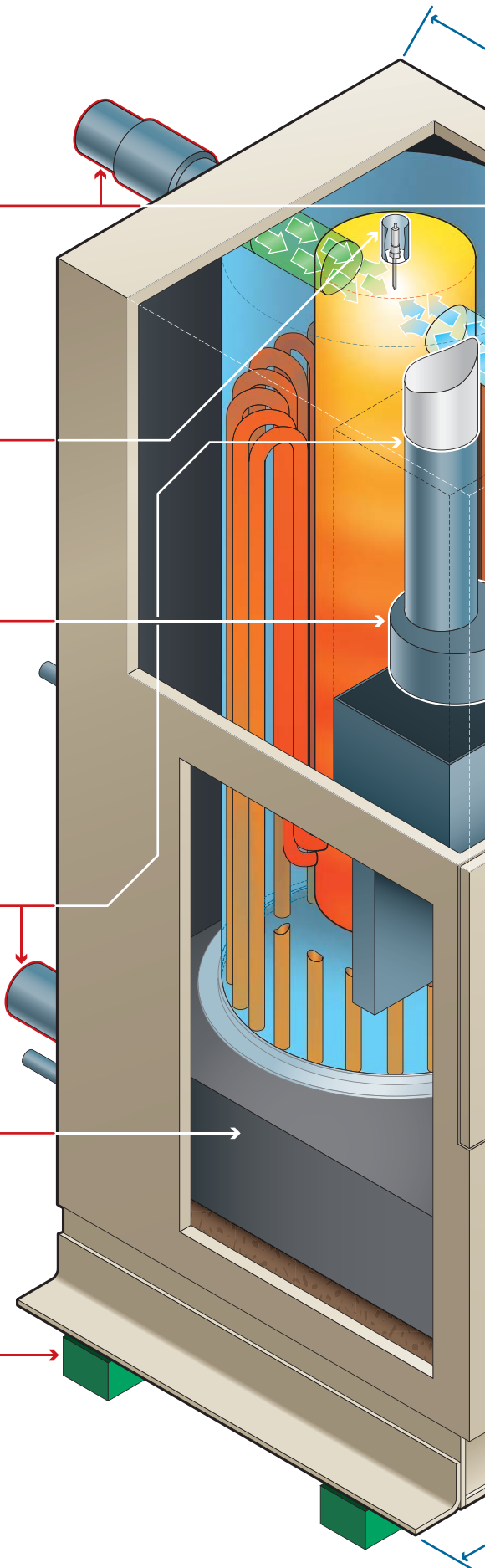

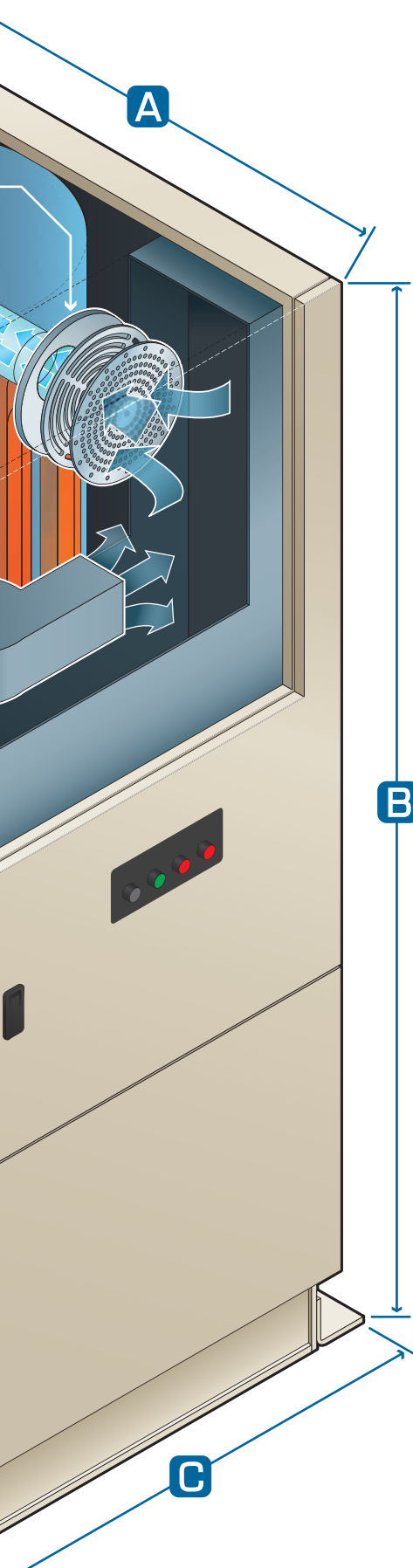

DIMENSIONS

	Model PHW	300	500	750	1000	1400	2000
A Boiler Depth	(INCHES) (MM)	37.8 959	37.8 959	37.8 959	37.8 959	50.0 1,270	55.0 1,397
B Boiler Height	(INCHES) (MM)	59.8 1,518	59.8 1,518	76.0 1,956	76.0 1,956	81.0 2,057	81.0 2,057
C Boiler Width	(INCHES) (MM)	27.5 699	27.5 699	27.5 699	27.5 699	33.6 855	33.6 855
Minimum Clearance To Walls	(INCHES) (MM)	1 26	1 26	1 26	1 26	1 26	1 26
Minimum Clearance to Front & Rear	(INCHES) (MM)	32 813	32 813	32 813	32 813	38 965	38 965



B VENTING

No masonry chimney is required. Each boiler can vent individually or vent collectively through a common header system. Intake and exhaust venting can be installed through a sidewall, a roof, or combination sidewall and roof.

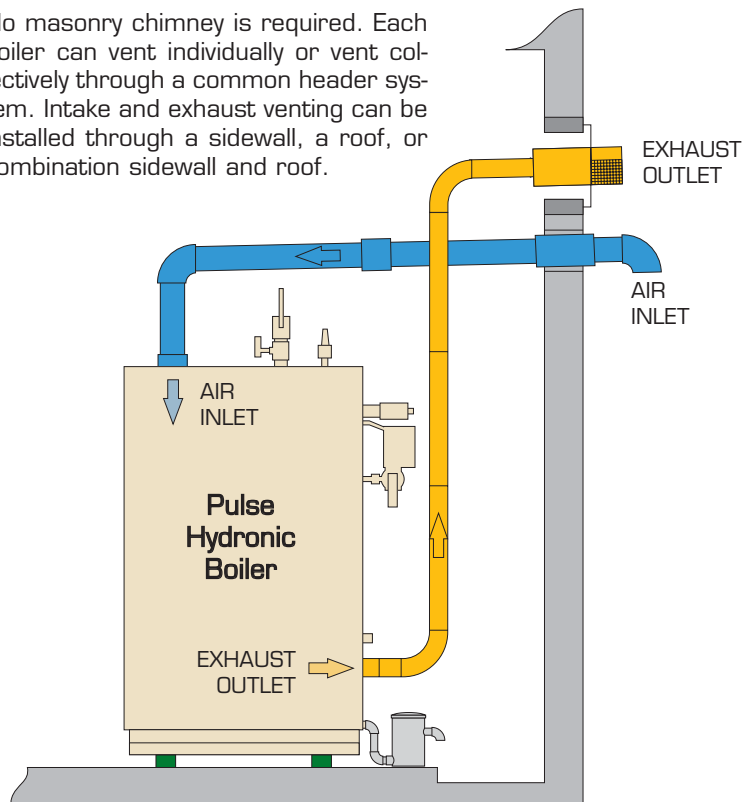

only with PULSE

Thermal Efficiency %

Thermal Efficiency vs. Return Water Temperature

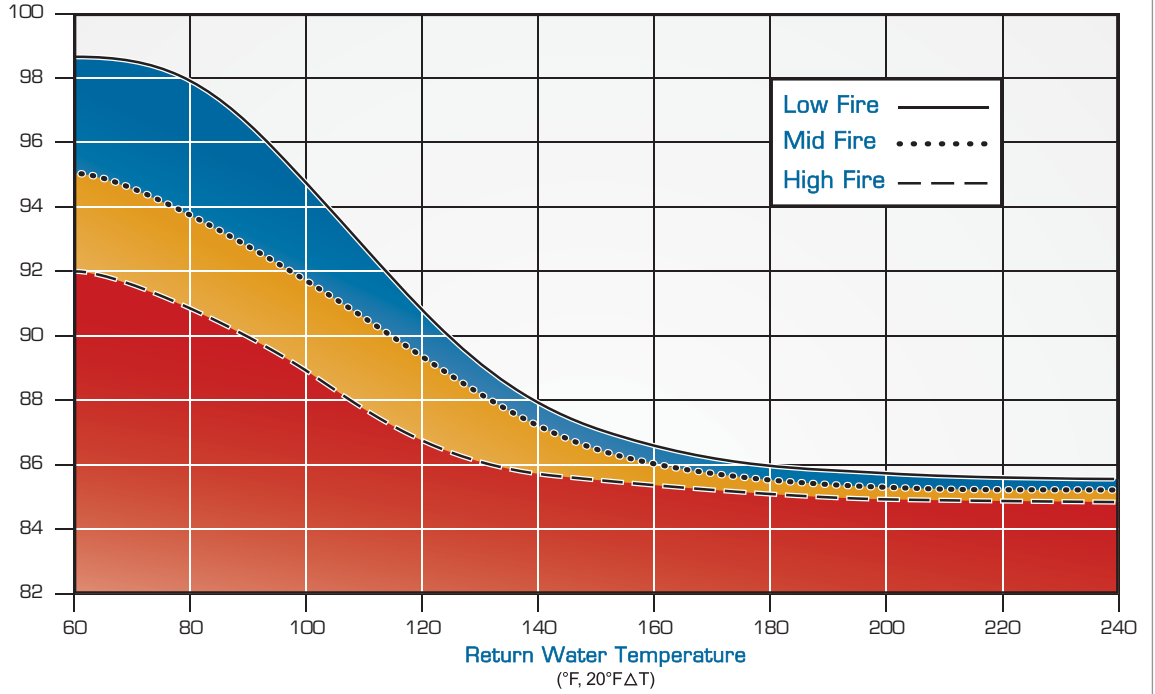

**Condensing,
Full Modulation
& Low Electrical
Consumption**

THE RESULT:
The highest seasonal efficiency available!

Pulse combustion eliminates the requirement of running a blower motor during boiler operation. Electrical consumption is less than 1 AMP, increasing the Pulse boiler's overall efficiency.

INSTALLATION & OPERATING COST COMPARISON

	Pulse Condensing Boiler	Typical Condensing Boiler	Typical Copper Fin
Blower Motor Operating Cost	Negligible	\$\$\$\$	\$\$\$\$
Minimum Flow Requirements	No Cost	\$\$	\$\$\$\$
Venting (Flue)	\$	\$\$	\$\$\$\$
Maintenance Costs	\$	\$\$\$	\$\$\$\$
Extended Parts Warranty	\$	\$\$\$	\$\$\$\$
Life Cycle Costs of Boiler	\$\$	\$\$\$	\$\$\$\$\$

INNOVATIVE

Solutions

Pulse combustion provides the maximum efficiency while consuming the least amount of electricity. The end result is the highest seasonal efficiency of any boiler available in the marketplace.

Contact Fulton today to find out if the Pulse Hot Water boiler is the solution that's right for you.



 **Fulton**[®]
Fulton Heating Solutions, Inc.
972 Centerville Road
Pulaski, NY 13142
Phone: 315.298.5121
Fax: 315.298.6390
www.fulton.com



A global manufacturer of steam, hot water and thermal fluid heat transfer systems.