

the best

# mod/con Performance and Versatility



Now with Floor and Wall Mount Models



High Efficiency Water Heaters, Boilers and Pool Heaters

[www.knightheatingboiler.com](http://www.knightheatingboiler.com)



# Legendary Performer...



Since its introduction in 2005, the KNIGHT modulating-condensing heating boiler has consistently delivered everything the professional needs for ease of installation and maintenance, and everything homeowners need for total comfort and long-term savings on energy costs.

Now, with 7 floor-standing models and 5 compact Wall Mount units, Lochinvar offers the industry's broadest selection of modulating-condensing heating boilers. And KNIGHT is the industry's most advanced boiler design, including the SMARTSYSTEM™

operating control that has quickly become a legendary benchmark among the trade!

For traditional space heating or radiant floor heating applications, KNIGHT offers your customers tremendous savings on energy costs compared to less efficient boilers. KNIGHT has earned the ENERGY STAR,

signifying that it has met strict energy-efficiency guidelines set by the EPA and U.S. Department of Energy.



**12 Models – The Right Choice, for Every Application**



*“After my first KNIGHT installation, I loved it so much I installed it in my own home, and now my heating bill is half what it used to be.”*

*– Rick Brunner, Hydronic Solutions, Nassau County, NY*

*KNIGHT is a great choice for radiant floor heating, baseboard and panel heater applications.*

# is joined at the Round Table



*"Why do I like the KNIGHT? I don't know where to begin. The direct venting with 100 feet of intake and exhaust eliminates a lot of problems. I also like the low voltage features, and the SMART SYSTEM's outdoor reset capability. The internal sequencer is tremendously powerful and ideal for multiple boiler installations. It's also great-looking, and aesthetics are important to my customers. When I install KNIGHT, my customers know they are getting a highly efficient state-of-the-art system, and they've all been completely satisfied."*

*— Paul Rohrs, Biggerstaff Radiant Solutions, Omaha, NE*



**KNIGHT lineup now includes 5 space-saving Wall Mount models from 50,000 to 210,000 Btu/hr**



**The KNIGHT floor-standing lineup features 7 small footprint designs from 80,000 to 500,000 Btu/hr**



All KNIGHT Boilers meet or exceed the highest federal emissions requirements.

**KNIGHT plus SQUIRE delivers domestic hot water for less!**

The KNIGHT boiler's DHWP feature means you can easily install it with Lochinvar's new SQUIRE indirect water heater. With this winning combination, homeowners will get high-efficiency space heating from KNIGHT, plus all the domestic hot water they need from SQUIRE. Equipped with a stainless steel tank and heat exchanger, SQUIRE will provide more hot water with lower water heating costs compared to a standard gas or electric water heater.



# with Heroic Quality and Innovation

**93%**  
DOE AFUE  
Efficiency

**98%**  
Efficiency  
in low-temp  
radiant  
applications

*"I'm very impressed with the KNIGHT Boiler. It's lightweight, simple to install and works remarkably well. The SMART SYSTEM control is a definite advantage, because most other manufacturers sell the control separately and it has to be assembled on the job. I also really like that the KNIGHT can modulate down to 20 percent, and that the wiring is very easy to understand. I recommend the KNIGHT to all of my customers who are looking for a quality boiler that will perform well and last for years."*

– Steve Ayotte, Ayotte's Water Works, Lansing, MI



## Advanced Negative Regulation Technology

KNIGHT safely and reliably operates with supply gas pressure as low as 4 inches water column, because "Neg/Reg" technology automatically adjusts fan speed to ensure the correct volume of fuel and air entering the burner.

## Fail-Safe Direct-Spark Ignition

With each call for heat, two electrodes ignite the fuel/gas mixture. A third electrode then senses for flame. If no flame is detected, the system resets and attempts ignition four times. SMART SYSTEM will lock out and display the fault if ignition does not occur after four attempts.

## Two-in-One Stainless Steel Heat Exchanger

A primary heat exchanger combined with a secondary heat exchanger capturing flue gas heat allows entering water temperatures as low as 50°F without a low-temperature bypass. The stainless steel, pH-tolerant design features a weld-sealed assembly with no O-rings or gaskets and does not require special glycol. ASME Section IV approved and stamped.

## Fully Modulating Burner with 5:1 Turndown

The SMART SYSTEM allows fully modulating combustion with 5:1 turndown. The burner can fire as low as 20% of maximum input, and modulates the firing rate up to 100% as demand increases. The woven stainless steel mesh assembly fires in a 360° pattern along the entire length of the heat exchanger. These together allow KNIGHT's compact size to excel compared to units with larger multiple burners.



# Ease of Installation

## Direct Venting up to 100 Feet!

KNIGHT offers greater flexibility than other boilers for placement of units within the building, because it permits direct-vent air intake and exhaust runs up to 100 equivalent feet, using 3" PVC or CPVC pipe. Wall-mounted KNIGHT models also permit intake and vent runs up to 40 feet using 2" pipe. Intake and exhaust runs can terminate horizontally through a sidewall or vertically through the roof.



# SMART SYSTEM™

# & the Industry's Smartest Design

SMART SYSTEM is the industry's most advanced operating control. Right out of the box, it gives you unequaled control and monitoring functions that are easy to understand and use.



"I really like the KNIGHT Boiler because it's very simple to install and program. The SMART SYSTEM control is great and I really like being able to troubleshoot with the pocket PC. My customers choose KNIGHT for its high efficiency and state-of-the-art design, and they're all thrilled that KNIGHT operates so quietly and makes their home much more comfortable."

— Chad Padilla, TLC Plumbing, Albuquerque, NM

### 2-Line, 16-Character LCD Display

Displays setup and diagnostic information in words, not codes

### Password Security

Dual passwords for installer and user

### Product Service Indicator

Program reminders for cycle count, operation hours or last service

### Pump Relay w/Freeze Protection

Ensures water temperature does not fall below 40°F

### Low-Water Flow Indicator

Protects against high temperature differential in the heat exchanger with reduced modulation or shutdown

### Outdoor Reset

Outdoor temperature monitor guides the reset schedule to meet load

### Night Setback

Program a temperature setback for any time of the day, each day of the week

### Building Management System (BMS) Control

0-10 VDC, BMS-driven input for modulation rate or temperature control

### DHWP with Pump Control

On call for hot water, SMART SYSTEM overrides outdoor reset and starts DHWP pump to the indirect. Runtime can alternate between heating and domestic hot water to meet demand simultaneously

### System & Boiler Pump Controls

Provides power to both system and boiler pumps based on a call for heat. Programmable delay allows pumps to operate after a call has been satisfied

### In/Out Temp. Sensors and Display

Allows installer to select which sensor controls the boiler setpoint



### PC Connection –

Can be used with KNIGHT PC or Pocket PC software to troubleshoot and program SMART SYSTEM functions and to track historical data, including faults, trends and energy consumption.

### Field Connection Versatility

User-friendly terminal strip allows for 28 low-voltage field connections. Plus, 4 line voltage connections supply power to the unit, and up to three pumps operated by the SMART SYSTEM.

### Built-in Cascading Sequencer

SMART SYSTEM includes a built-in sequencer for 2–8 units, eliminating the cost and labor of a third-party sequencer. On demand, one boiler acts as lead unit and modulates with demand to meet capacity. The additional load then "cascades" to the next boiler in line and continues all are operating or demand is satisfied. When demand drops, the process reverses.



"The control system on the KNIGHT is head and shoulders above anything else available. Straight out of the box, the KNIGHT can do anything I need without third-party controls. Hands-down, it's the best boiler on the market."

— Don Smet, Standard Plumbing Heating Controls Corp., Spokane, WA



## Knight Heating Boiler Dimensions & Specifications– Floor Standing Models

## Wall Mount Models

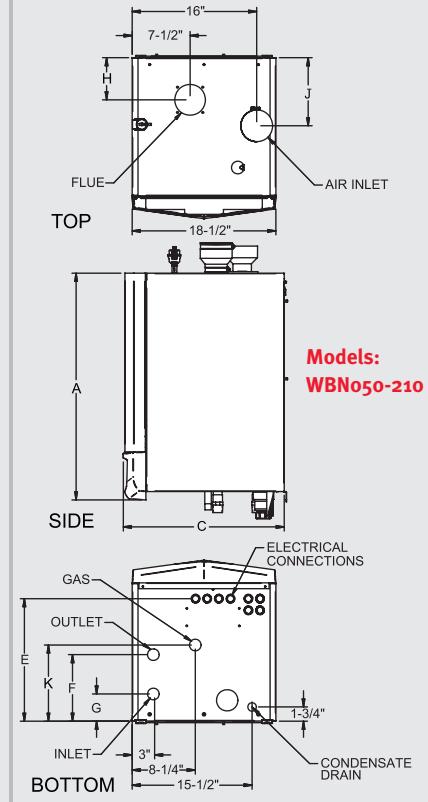
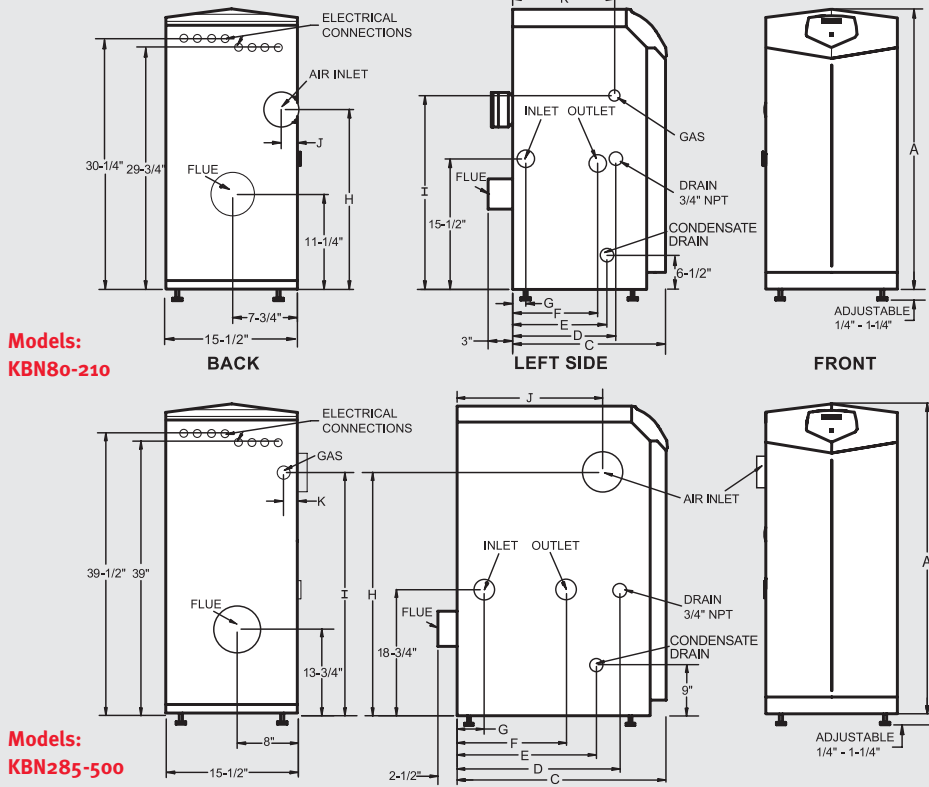

Model Number	Btu/Hr Input Modulation	Max. Btu/Hr Output	Net I=B=R	A	C	D	E	F	G	H	I	J	K	Water Conn.	Gas Conn.	Air Inlet	Vent	Ship. Wt.
KBN080	16,000 - 80,000	73,000	63	33-1/4"	14"	7"	5-3/4"	5"	3"	20-1/2"	22"	1-3/4"	6-1/2"	1"	1/2"	3"	3"	125
KBN105	21,000 - 105,000	95,000	83	33-1/4"	14"	6-1/2"	5-3/4"	4-1/2"	1-1/2"	20-1/2"	22"	1-3/4"	6-1/2"	1"	1/2"	3"	3"	129
KBN150	30,000 - 150,000	136,000	118	33-1/4"	18"	12-1/4"	11-1/2"	10"	1-1/2"	21-1/4"	23"	1-3/4"	12"	1"	1/2"	3"	3"	157
KBN210	42,000 - 210,000	191,000	166	33-1/4"	22-1/4"	16-1/2"	15-3/4"	14-1/4"	5-1/4"	21-1/4"	23"	1-3/4"	16-1/4"	1"	1/2"	3"	3"	172
KBN285	57,000 - 285,000	259,000	225	42-1/2"	19-3/4"	12-3/4"	13-1/2"	6"	2"	34"	31"	11-3/4"	4-1/4"	1-1/4"	3/4"	4"	4"	224
KBN399	79,800 - 399,000	360,000	313	42-1/2"	27"	21"	20-3/4"	14"	3-1/2"	34"	34"	18-3/4"	2"	1-1/2"	1"	4"	4"	285
KBN500	100,000 - 500,000	451,000	392	42-1/2"	31-1/4"	21"	25"	14"	3-1/2"	35"	35"	22"	5-3/4"	1-1/2"	1"	4"	4"	305
WBN050	10,000 - 50,000	45,000	39	29-1/4"	15-3/4"	N/A	10-3/4"	TBD	TBD	6-3/4"	N/A	3-1/4"	4-1/4"	1"	1/2"	2"	2"	130
WBN080	16,000 - 80,000	73,000	63	29-1/4"	15-3/4"	N/A	10-3/4"	TBD	TBD	6-3/4"	N/A	3-1/4"	4-1/4"	1"	1/2"	2"	2"	130
WBN105	21,000 - 105,000	95,000	83	29-1/4"	15-3/4"	N/A	10-3/4"	TBD	TBD	5-1/2"	N/A	3-1/4"	4-1/4"	1"	1/2"	2"	2"	134
WBN150	30,000 - 150,000	136,000	118	29-1/4"	20-3/4"	N/A	15-3/4"	TBD	TBD	5-1/2"	N/A	8-3/4"	9-3/4"	1"	1/2"	3"	3"	162
WBN210	42,000 - 210,000	191,000	166	29-1/4"	25"	N/A	20"	TBD	TBD	5-1/2"	N/A	13"	14"	1"	1/2"	3"	3"	177

Notes: Performance data based on manufacturer's test results. Indoor installation only. All information subject to change. Change "N" to "L" for LP gas models.

Standard features in **BOLD** text indicate equipment you would pay extra for on competing models.

### Standard Features

- › 93% AFUE Efficiency (KBN080-285) (WBN050-210)
- › 95% Thermal Efficiency (KBN399-500)
- › ENERGY STAR® Qualified
- › Modulating Burner with 5:1 Turndown
- › ASME Stainless Steel Heat Exchanger
- › Gasketless Heat Exchanger Design
- › 30 psi Relief Valve (KBN080-285) (WBN050-210)
- › 50 psi Relief Valve (KBN399-500)
- › **SMART SYSTEM™ Operating Control, with:**
  - Digital Operating Control
  - 2-Line, 16-Character LCD Display
  - Password Security
  - Outdoor Reset
  - Built-in Sequencing for 2-8 Boilers
  - 0 – 10 Vdc Input Control
  - Product Service Indicator
  - Time Clock
  - PC Connection Port
- › Inlet & Outlet Temperature Sensors
- › Easy-Access Terminal Strip
- › Low-Water Flow Indication
- › Automatic Reset High Limit
- › **Contacts on Any Failure**
- › **3-Pump Control (Boiler, System and DHWP)**
- › Pump Relay with Freeze Protection
- › **Boiler Circulating Pump (KBN080-285) (WBN050-210)**
- › Direct-Spark Ignition
- › Low-NOx Operation
- › Natural to LP Gas Conversion Kit
- › Direct-Vent Sealed Combustion
- › PVC Venting up to 100 Feet
- › Sidewall Vent Terminals
- › Zero Clearance to Combustibles
- › Adjustable Leveling Legs (KBN Models only)
- › Wall Mount Bracket (WBN Models only)
- › 12-Year Limited Warranty (See Warranty for Details)

### Optional Equipment

- › Adjustable High Limit with Manual Reset
- › Flow Switch
- › Low-Water Cutoff with Manual Reset and Test
- › High & Low Gas Pressure Switches (KBN500)
- › Alarm Bell on Any Failure
- › SMART SYSTEM™ PC Software
- › Concentric Vent Kit
- › Condensate Neutralization Kit
- › Multi-Stack Frame (KBN Models only)

