



PulsePak

Sizes ranging from 300,000 to 2,000,000 Btu/hr

State of the art boilers offer efficiencies up to 98% and modulation with 5:1 turndown.



Fulton PulsePak Pulse Combustion Hydronic Boilers

A PulsePak boiler operates with a standard efficiency of approximately 84-90%. For optimum performance Fulton's PulsePak can be ordered with modulation which results in efficiencies of up to 98%. Fulton Models PHW 1400 and PHW-2000 are supplied with modulation as standard equipment.

Fulton Pulse boilers utilize state-of-the-art technology to achieve full modulation. The result is a boiler that offers up to a 5:1 turndown for precise load matching capability. Sound deadening features bring the DBA to less than 72 on all PulsePak boilers -- more quiet than most other HVAC equipment.

High Efficiencies, Low Exhaust Temperatures Feature Side Wall Venting

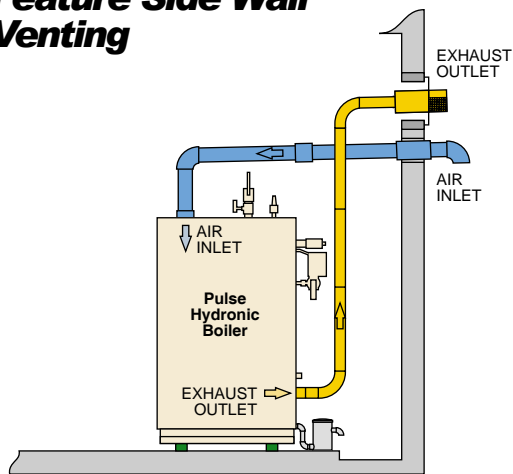

Benefits with Pulse

- Standby losses are nearly zero.
- Small footprint allows installation in multiple buildings or in isolated areas of large plants.
- Fit through standard door openings.
- No power burner combined with the pulse design, results in the lowest maintenance requirements in the industry.
- No primary/secondary loop required to maintain minimum return water temperature.
- Pulse combustion produces inherently lower NOx levels than conventional boilers.
- No minimum or maximum flow requirements.

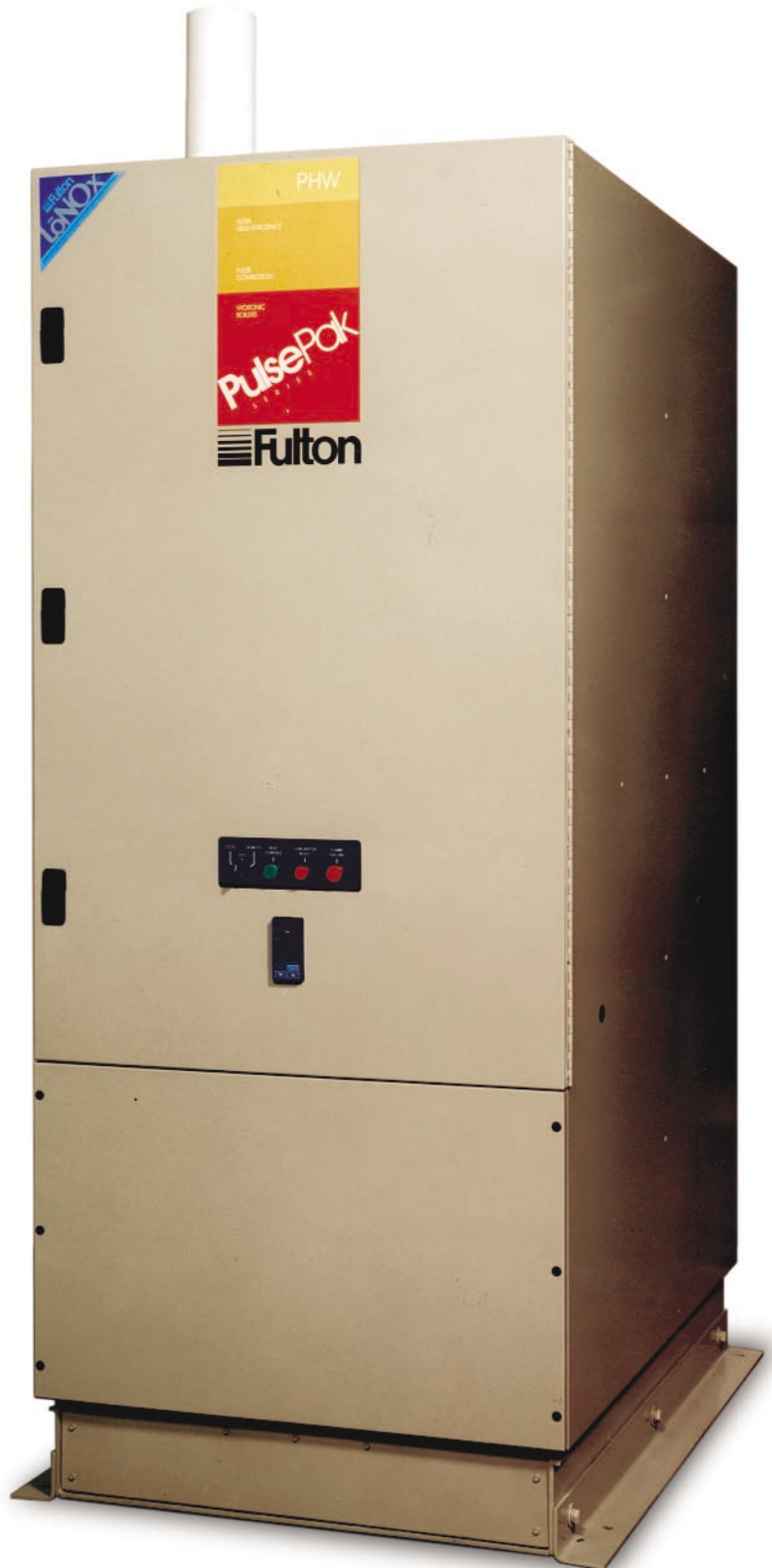



Shown above is a modular installation of six PHW1400 Fulton Pulse Combustion Boilers. Multiple boilers are staged to maximize the time spent at the lowest firing rate, thus maximizing efficiencies.

Highest efficiencies imaginable with Pulse

Standby losses are nearly non-existent. The combustor and exhaust tail pipes are surrounded by water. The pulse process transfers more heat per square inch than conventional processes, making it the most efficient way of burning fuel. When the boiler's set point is less than 140°F, the boiler will produce condensation which extracts latent heat from the flue gases, producing extremely high efficiencies – up to 98%.

Additional Benefits

- Standby losses are nearly zero.
- No minimum return water temperature requirement.
- Optional 316L stainless steel combustion chamber & exhaust pipes.
- Optional sequencing controller for on/off and modulated boilers.
- Optional outdoor reset will maximize seasonal efficiency.



Optional sequencing controller from Fulton is recommended for multiple boiler installations. This control increases seasonal efficiencies by 5-10%, and is capable of operating 2-20+ boilers as an integral system. This control can also operate pumps, valves, and domestic hot water systems.

98% efficiency can be achieved with modulation

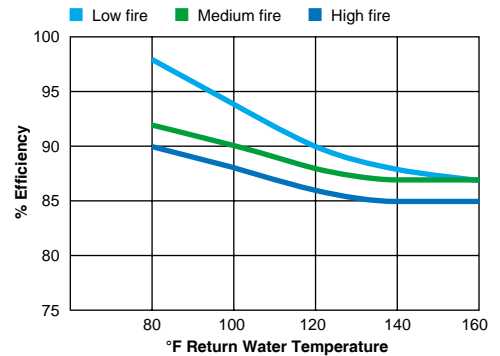

Flue gas temperature

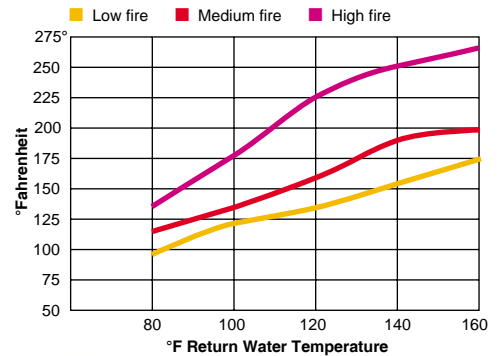

The PHW1400 and PHW2000 PulsePak boilers come with a single modulation controller mounted in the front panel as standard equipment.

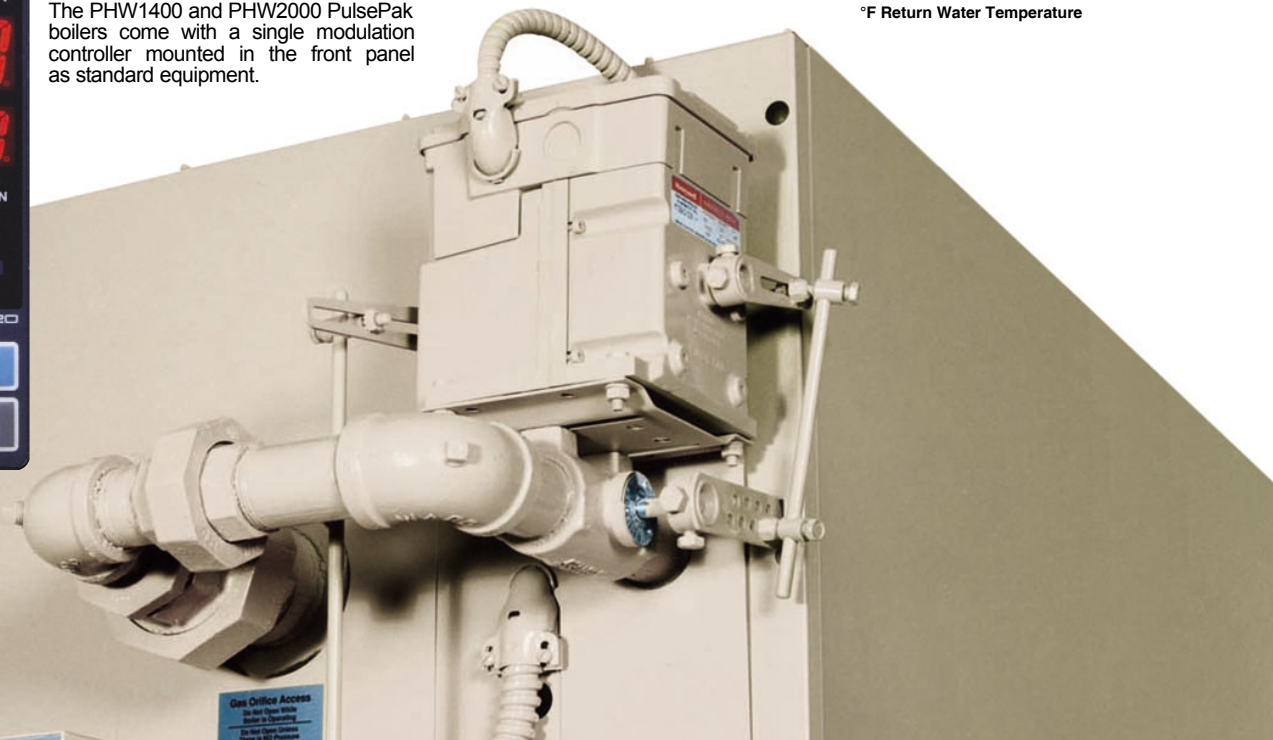

Specifications/Dimensions

Model PHW		300	500	750	1000**	1400	2000
Fuel		N. Gas or Propane	N. Gas or Propane	N. Gas or Propane	N. Gas or Propane	N. Gas or Propane	N. Gas
Input	Btu/hr.	300,000	500,000	750,000	1,000,000	1,400,000	2,000,000
	KCAL/HR.	75,600	126,000	189,000	252,000	352,644	503,992
Output*	Btu/hr. (120°F in-140°F out)	270,000	440,000	637,500	840,000	1,204,000	1,680,000
	KCAL/HR. (49°C in-60°C out)	68,000	110,885	160,698	211,700	303,420	423,353
Fuel Consumption @ rated capacity							
Natural Gas	FT ³ /Hr.	300	500	750	1000	1400	2000
	M ³ /Hr.	8.5	14.2	21.2	29.3	39.6	56.6
Propane	FT ³ /Hr.	120	200	300	400	560	
	M ³ /Hr.	3.4	5.7	8.5	11.4	15.9	N/A
Modulation		Optional	Optional	Optional	Optional	Standard	Standard
Turn Down Ratio		3:1	5:1	5:1	5:1	5:1	5:1
Unit Size/Output	HP	8	13	19	30	36	50
	KW	80	130	190	295	355	493
Electrical Requirements							
120V, 60 CY, 1 Phase	Amps	4.0	4.0	4.0	4.0	4.0	13.0
		2.0	2.0	2.0	2.0	2.0	7.0
240V, 50 CY, 1 Phase							
MAWP	PSI	60/100	60/100	60/160	60/160	60/160	60/160
	BAR	4.1/6.9	4.1/6.9	4.1/11.0	4.1/11.0	4.1/11.0	4.1/11.0
Water Content	GAL	34	34	42	42	80	75
	LITERS	129	129	159	159	303	284
Approximate Shipping Weight	LB	1,495	1,495	1910	1910	2660	2900
	KG	680	680	866	866	1206	1316
Approximate Operating Weight	LB	1,680	1,680	2150	2150	3195	3500
	KG	737	737	975	975	1450	1588
A. Boiler Width	IN	27.5	27.5	27.5	27.5	33.6	33.6
	MM	699	699	699	699	855	855
B. Boiler Height	IN	59.8	59.8	76	76	81	81
	MM	1,518	1,518	1956	1956	2,057	2,057
C. Boiler Depth	IN	37.8	37.8	37.8	37.8	50	55
	MM	959	959	959	959	1,270	1,397
Air Inlet	IN	3	3	4	4	4	6
	MM	76	76	102	102	102	152
Gas Inlet	IN	1	1	1	1.25	1.50	1.50
	MM	25	25	25	31.75	38.1	38.1
Exhaust Outlet	IN	3	3	4	4	4	6
	MM	76	76	102	102	102	152
Water Inlet	IN	2	2	2	2	2.5	4
	MM	51	51	51	51	64	102
Water Outlet	IN	2	2	2	2	2.5	4
	MM	51	51	51	51	64	102

*Output Btu/hr based on 120°F in--140°F out; Output KCAL/HR based on 49°C in--60°C out Continual improvement reserves Fulton the right to change specifications when necessary.

** The PHW1000 is also available with an input of 950,000 Btu/hr.

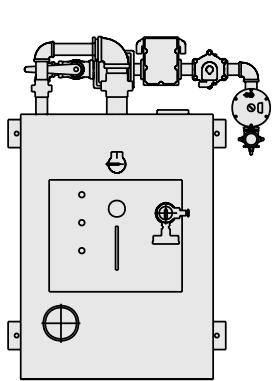

Note:
ASME code limits the outlet water temperature to a maximum operating temperature of 200°F for Stainless steel combustor and 240°F for Carbon steel combustor.

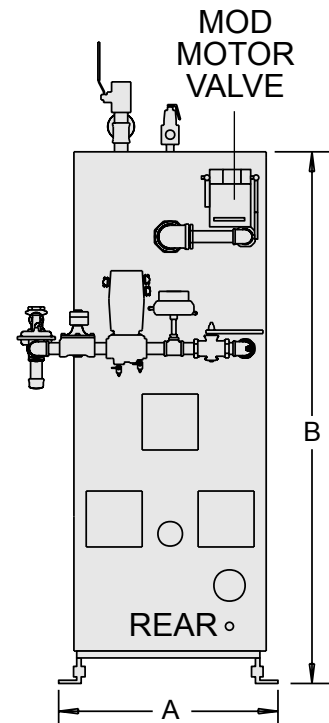
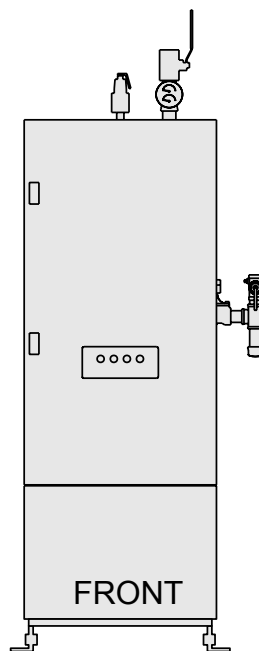
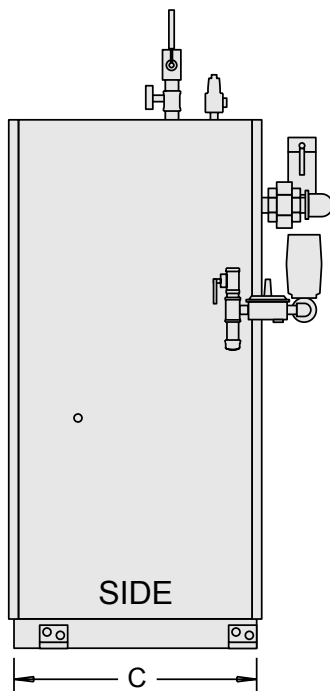

Fulton Pulse Combustion is reliable, ultra efficient, and it sidewall vents without a chimney.

These few parts are the “heart” of pulse combustion.

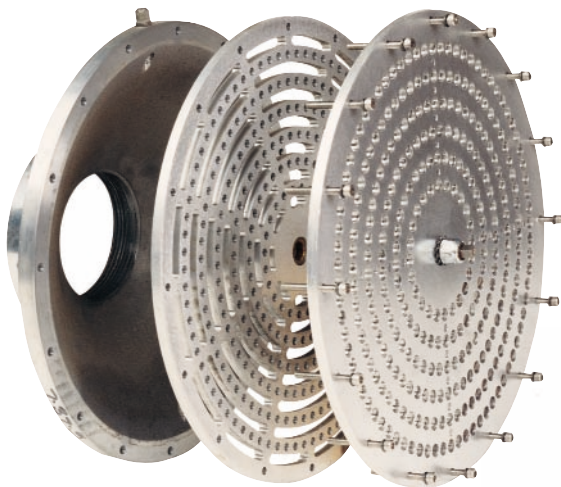

◀ Flapper Valves



Assist Fan ▶



▶ Spark Plug



◀ Controller

▶ Electrical Control Panel

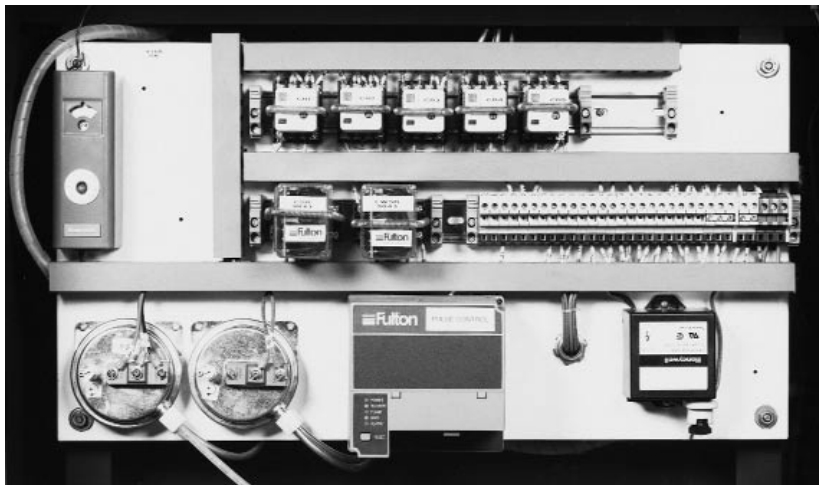

- ▶ The patented air and gas valves are composed of specially designed plates with teflon membranes between them. These valves are preset at the factory.
- ▶ The spark plug ignites the air and gas when heat is called for. After ignition, the spark plug is signaled to turn off.
- ▶ The fan is used for purge process only... there is no fan on during the run mode.
- ▶ For ease of access, the operating and safety controls are centrally located on one main panel behind the front door.
- ▶ The 7865 provides safety, reliability and fully automatic burner sequencing, system status, and self diagnostics for trouble shooting. Options include keyboard and display module, remote mounting, and PC interface capabilities.

Principal and operating phases of pulse combustion

The pulse combustion process does not utilize a power burner. It has no moving parts. Combustion takes place in a sealed environment and it is similar to an internal combustion engine.

First a charge of air and gas enters through the individual metering valves into the combustion chamber. The charge initially ignites with a spark plug.

Combustion takes place and the spark plug shuts off. The positive pressure from combustion closes both intake metering valves and forces the hot gases out the tail pipes into the exhaust chamber.

Nearly simultaneously the air and gas metering valves are sucked open (negative pressure in the combustor)

from the process to admit a fresh charge of air and gas.

These positive and negative combustion pressure phases repeat many times a second at a natural frequency.

Component View - PulsePak Pulse Combustion Boilers

300,000; 500,000; 750,000; 1,000,000; 1,400,000 and 2,000,000* Btu/hr.

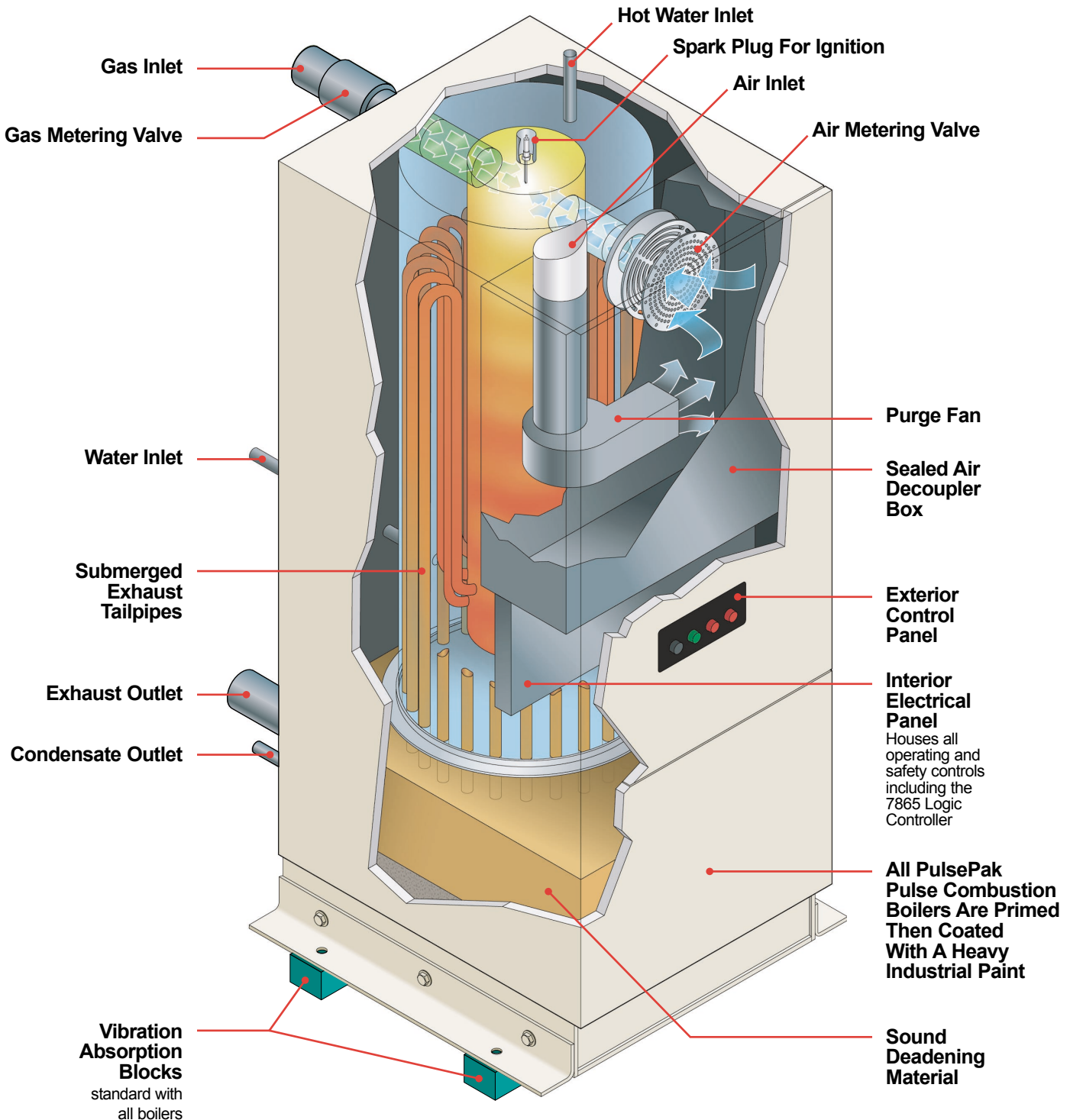

PulsePak Warranty

PulsePak boilers have a 10 year thermal shock warranty covering a 170°F differential across the boiler, a 5 year warranty on the stainless tailpipe assembly or a 3 year warranty on the carbon steel units, and a full ten year warranty on the pressure vessel.

* Air and Fuel delivery are typical for PHW300-PHW1400 only.

Venting Configurations With Pulse Combustion Boilers

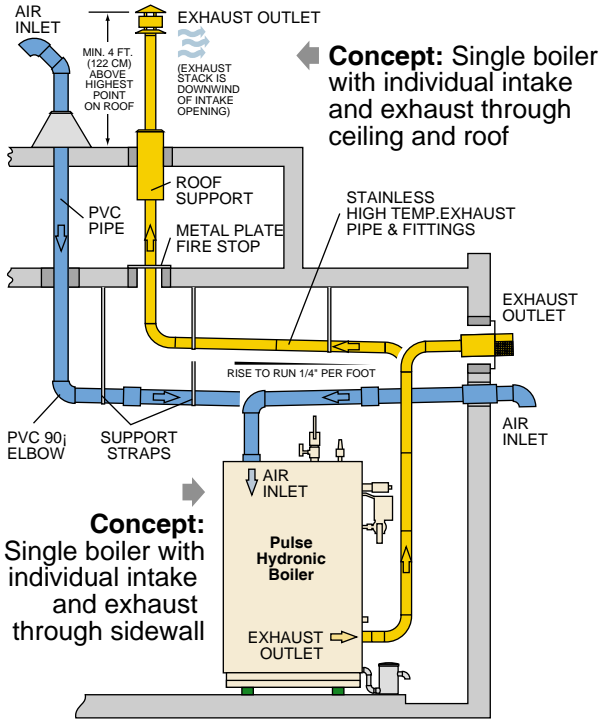

A conventional boiler burner extracts air from the boiler room. An air damper must be opened to let air in when the boiler is running. Therefore, the boiler room needs heating to avoid freezing. With a sealed combustion system associated with pulse combustion, the air is drawn into the boiler from outside the boiler room through small diameter PVC tubing. Exhaust exits from the boiler via small diameter stainless tubing.

Pulse boilers can vent in many different ways

No masonry chimney is required. Each boiler can vent individually or vent collectively through a common header system. Intake and exhaust venting can be installed through a sidewall, a roof, or combination sidewall and roof.

Multiple boilers venting through common intake and exhaust manifolds have fewer building penetrations with unlimited venting lengths.

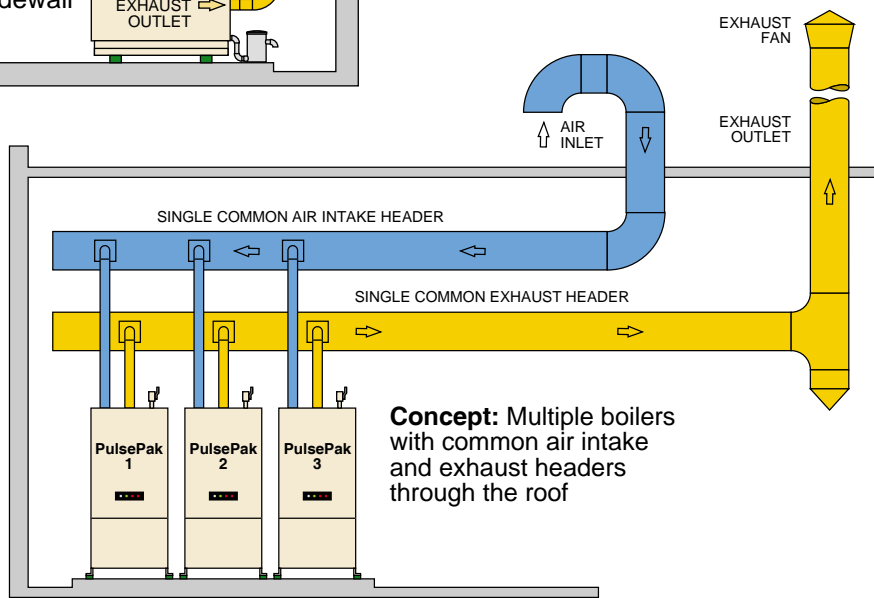

This installation is equipped with an end-of-the-line exhaust fan.

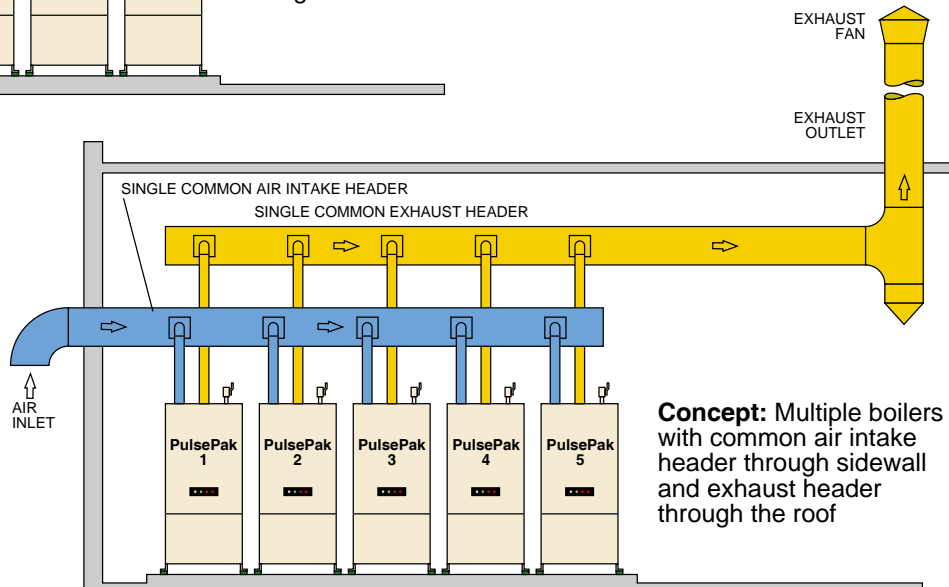



A global manufacturer of
steam, hot water and thermal
fluid heat transfer products.

www.fulton.com

Fulton Boiler Companies

3981 Port Street, Box 257
Pulaski, NY 13142

Phone: 315-298-5121

Fax: 315-298-6390

Email: info@fulton.com

