

eVent™ Series
Chimney System
for
High Efficiency Appliances

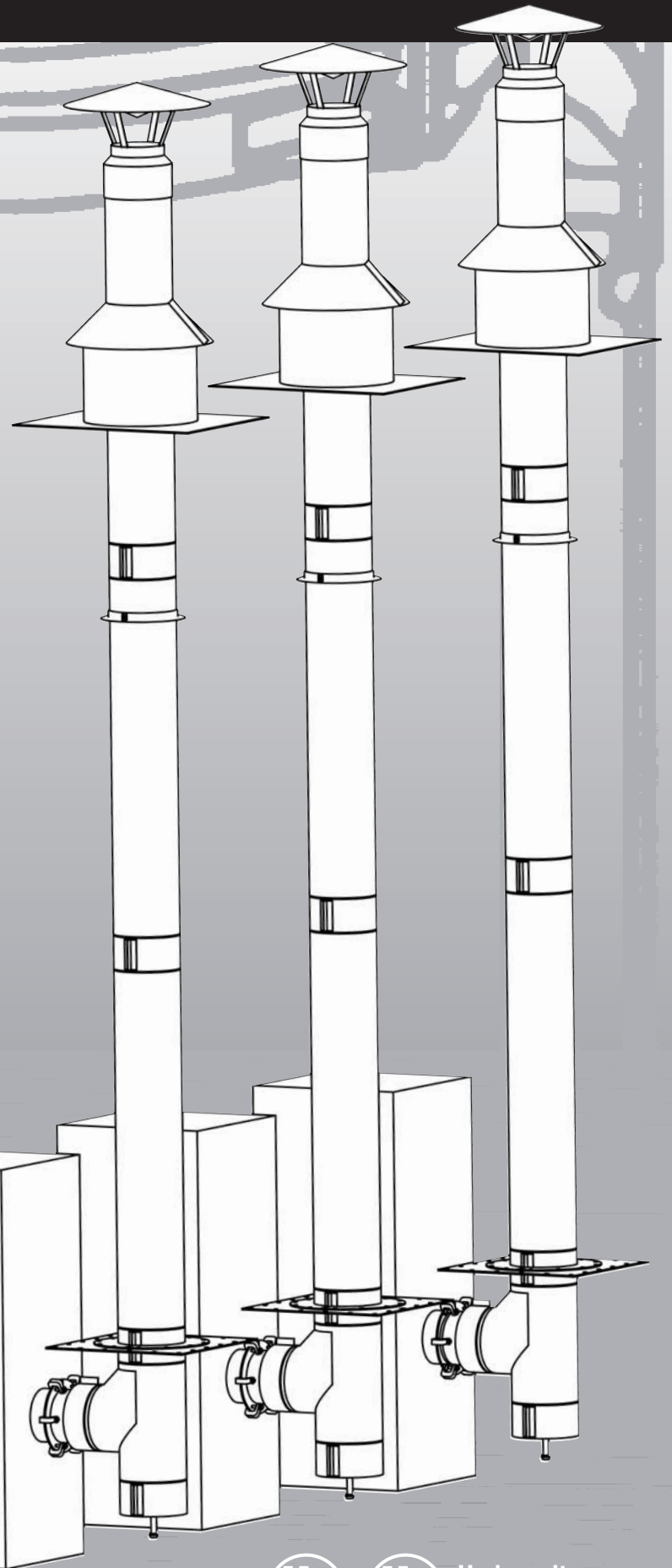
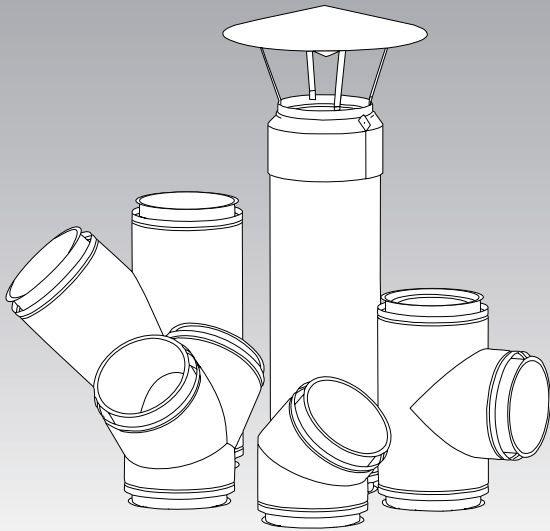

LISTINGS

The Schebler eVent and eVentPLUS system are tested and listed by Underwriters Laboratories Inc. (UL) under file number MH10056 for UL 1738 and ULC S636-95 vent.

SYSTEM CONCEPT

eVent and eVentPLUS are modular double wall prefabricated vent and exhaust systems used in venting high efficiency appliances that require a positive, neutral or negative draft exhaust. Sections are provided in lightweight, easy-to-handle lengths. Connections are sealed with pressure tight drawbands and high temperature sealant. Straight sections, variable length joints, tees, elbows and support devices are offered, allowing a complete exhaust system to be assembled from standard components. The eVent and eVentPLUS have a 1" air gap between the inner and outer shell. eVentPLUS2 model is available as well which has a 2" gap between liners filled with ceramic insulation. See eVentPLUS2 brochure for more information.

VENTING APPLICATIONS

eVent and eVentPLUS are double wall special stainless steel venting system for gas fired appliances listed as Category II, III, & IV with a maximum flue gas temperature of 550° F, and 40" w.c. positive pressure. Gas vent - BH, Class I/Class II - 245° C . eVent is also suitable for other applications that call for an AL 29-4C vent.

COMPLETE LINE OF FITTINGS AND SIZES AVAILABLE

The eVent series is available in even and odd diameters ranging from 5" to 48". A complete line of Straight Sections, Variable Lengths, Tee's, Elbows, Rain Caps, Roof Penetration components and support members are offered. In addition to the standard components virtually any conceivable fitting is available as a special order item.

MATERIALS AVAILABLE

eVent is available in a variety of materials allowing the proper material selection for your specific application. The standard product features an AL 29-4C stainless steel liner and an aluminized steel outer shell.

For exterior installations which are not easily accessible for periodic painting, you should consider a 304, 430 or 316 Stainless Steel outer shell which will require no maintenance.

MATERIAL THICKNESS

The standard material thickness for eVent liners is 24 ga. (.024"); for shells it is 22 ga. (.030"). eVentPLUS material thickness is 20 ga. (.035") for liners and 22 ga. (.030") for shells.

SEE OUR WEBSITE FOR OUR OTHER CHIMNEY MODELS
www.scheblerchimney.com

TESTS PERFORMED

eVent and eVentPLUS have endured rigorous tests by Underwriters Laboratories. Just a few of the tests performed are:

- **Structural Tests** The support plates and wall supports have been physically tested to carry a load 4 times that allowed by our listing.
- **Wind Load Tests** Loads equivalent to 110 mph wind have been applied to the vent with acceptable results.
- **Pressure Tests** UL tested to 40" w.c. positive pressure.
- **Leak Tests** Joints have been UL tested for non-leakage.
- **Rain Tests** The rain caps have been tested to ensure that an unsatisfactory amount of water does not enter the rain cap.

UNIQUE FEATURES

The eVent series offers some unique features that no other vent manufacturer can provide.

- *Union made with the fastest lead times in the industry.*
- *The eVent series uses fast, easy and proven inner band joint connections in lieu of a gasketed male / female end connections.*
- *Special fittings are available which are an asset in tight installation environments. Other manufacturers only offer catalog parts.*
- *All of our liners and shells are continuously seam welded. We do not use spot welds on any of our seams. This assures a leak proof joint and maximum strength. This also minimizes corrosion, adding longevity to the stack.*
- *We do not use captive nuts and bolts. If you have ever installed a system that uses these types of bolts you know how difficult it can be to align and get a nut started on a bolt. Also you do not scrap a band if a nut gets stripped or damaged. All hardware can be easily located at your local hardware store in case of emergency.*
- *Our boiler adapters include a seal ring to cover the gap between the liner and shell.*
- *ISO 9001:2000 Registered*
- *Largest diameters in the industry.*
- *Best support limits in the industry.*
- *Highest pressure rating of 40" w.c.*

SUPPORT LIMITS

Support plates and Wall supports are utilized to support the weight of the vent. In horizontal runs, supports should be placed adjacent to fittings that are not otherwise supported. See the individual part description for allowable support charts.

OPERATING TEMPERATURES AND CLEARANCES CHART

eVent and eVentPLUS have been tested and listed for a maximum flue gas temperature of 550°F, and ULC-S636-95 for gas vent-BH, Class I/Class II - 245°C. The clearances shown are from the shell to combustibles.

eVent Series Clearance to Combustibles

Section Inside Diameter	550°F (288°C)
6"	1" (25mm)
8"	1" (25mm)
10"	1" (25mm)
14"	1" (25mm)
16"	1.5" (38mm)
18"	1.5" (38mm)
20"	1.5" (38mm)
22"	2" (51mm)
24"	2" (51mm)
26"	3" (76mm)
28"	3" (76mm)
30"	3" (76mm)
32"	3" (76mm)
34"	4" (102mm)
36"	4" (102mm)
38"	4" (102mm)
40"	4" (102mm)
42"	4" (102mm)
44"	5" (127mm)
46"	5" (127mm)
48"	5" (127mm)

Clearance to non-combustible materials for all diameters and applications is 0" (0mm).

PART NUMBERS

All standard parts manufactured by Schebler are identified by a part number which describes their make up and function.

The part numbers are made up as follows:

1. The first series is the model designation EV (eVent) and EVP (eVentPLUS).
2. This is followed by the part name. For example 47S, 90T, and CC.
3. Next is the part's internal diameter in inches, such as 06, 12, 24.
4. Last is the liner/shell material designation.

CODE	LINER/SHELL MATERIAL
F	Galvanized
G	Aluminized
H	Painted Carbon Steel
K	AL29/Aluminized
L	AL29/304
M	AL29/316
R	AL29/430

For example, the Part Number for an 8" ID, eVent, 47" long straight section with an AL 29-4C stainless steel liner and aluminized steel shell is: EV47S08K.

JOINT ASSEMBLY

1. Apply a continuous ¼" bead of the proper sealant to one of the flanges being joined.
2. Join the two flanged ends of the sections.
3. Fill the "V" in the inner band with the proper sealant.
4. Install the inner band around the flanges and tighten the screws.
5. Tap around the inner band with a rawhide mallet and retighten the screws to ensure a tight joint.
6. Place the outer band over the space between the shells of the adjoining sections and tighten the screws. NOTE: For outdoor installations, apply a bead of S600 sealant in the groove at the upper end of the outer band.

SEALANT

Schebler S600 is used for all eVent applications.

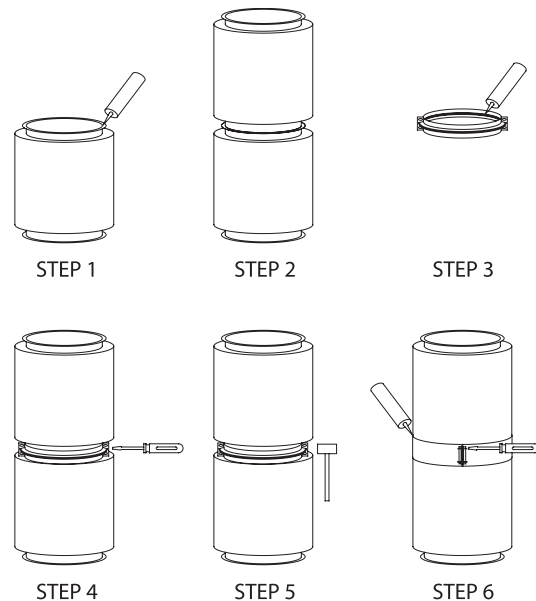
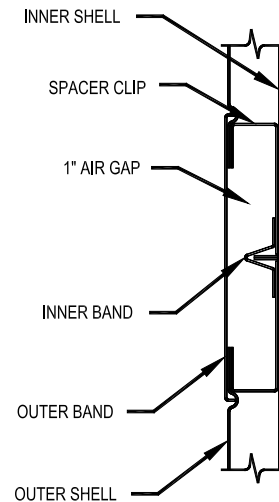

SYSTEM COMPONENTS

CUSTOM DIMENSIONS ARE AVAILABLE TO SUIT YOUR NEEDS IN EVEN AND ODD SIZES

ADAPTER KIT (FLANGED)

Part No. BKF

The Adapter Kit Flanged is used for securing pipe to a flanged appliance outlet. Beam clamps are provided for connection of the flanges or the flange can be drilled in the field to match the appliance.

Includes 1 inner band and 1 seal ring to cover the gap between the inner and outer shells.

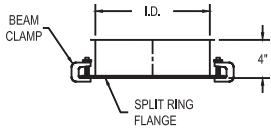

Part No. BKF	
I.D.	CLAMPS
6"	3
8"	4
10"	5
12"	6
14"	7
16"	8
18"	9
20"	10
22"	11
24"	12
26"	13
28"	14
30"	15
32"	16
34"	17
36"	18
38"	19
40"	20
42"	21
44"	22
46"	23
48"	24

ADAPTER KIT (RAW)

Part No. BKR

The Adapter Kit Raw is used for securing pipe to an unflanged appliance outlet.

Includes 1 inner band and 1 seal ring to cover the gap between the inner and outer shells.

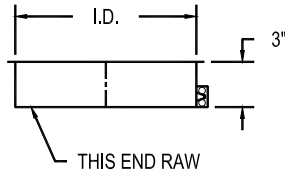

Part No. BKR

I.D.
6"
8"
10"
12"
14"
16"
18"
20"
22"
24"
26"
28"
30"
32"
34"
36"
38"
40"
42"
44"
46"
48"

STRAIGHT SECTION

Part No. 18S, 35S, 47S, 59S

Standard lengths are as follows:

Diameter 6" is 18", 35" and 47"

Diameter 8"-10" is 18", 35", 47" and 59"

Diameter 12"-48" is 18" and 35"

Custom parts can be manufactured to any length over 8".

Includes 1 inner and 1 outer band.

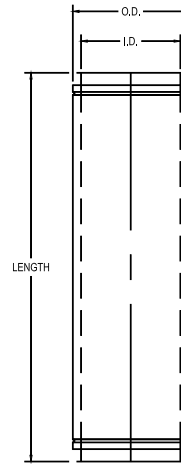

Part No. 18S/35S/47S/59S

I.D.	O.D.
6"	8"
8"	10"
10"	12"
12"	14"
14"	16"
16"	18"
18"	20"
20"	22"
22"	24"
24"	26"
26"	28"
28"	30"
30"	32"
32"	34"
34"	36"
36"	38"
38"	40"
40"	42"
42"	44"
44"	46"
46"	48"
48"	50"

VARIABLE LENGTH SECTION

Part No. 18VS, VS

The Variable Section adjusts to provide a fixed odd length between 2 sections. The minimum length is 5", the maximum is 18" or 35". This part does not provide for thermal expansion.

Includes liner, shell, slip joint, and 1 inner band.

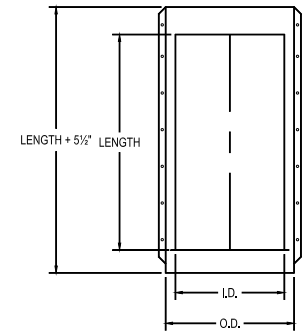
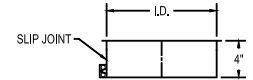

Part No. 18VS/VS

I.D.	O.D.
6"	8"
8"	10"
10"	12"
12"	14"
14"	16"
16"	18"
18"	20"
20"	22"
22"	24"
24"	26"
26"	28"
28"	30"
30"	32"
32"	34"
34"	36"
36"	38"
38"	40"
40"	42"
42"	44"
44"	46"
46"	48"
48"	50"





TAPERED INCREASER

Part No. TI

The Tapered Increaser is used when a change in pipe diameter is required.

Includes 1 inner and 1 outer band of both smaller and larger size.

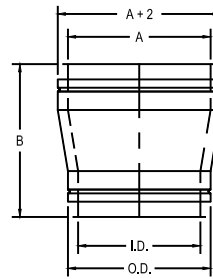

Part No. TI								
I.D.	A	B	A	B	A	B	A	B
6"	8"	15"	10"	18"	12"	21"	14"	24"
10"	12"	15"	14"	18"	16"	21"	18"	24"
12"	14"	15"	16"	18"	18"	21"	20"	24"
14"	16"	15"	18"	18"	20"	21"	22"	24"
16"	18"	15"	20"	18"	22"	21"	24"	24"
18"	20"	15"	22"	18"	24"	21"	26"	24"
20"	22"	15"	24"	18"	26"	21"	28"	24"
22"	24"	15"	26"	18"	28"	21"	30"	24"
24"	26"	15"	28"	18"	30"	21"	32"	24"
26"	28"	15"	30"	18"	32"	21"	34"	24"
28"	30"	15"	32"	18"	34"	21"	36"	24"
30"	32"	15"	34"	18"	36"	21"	38"	24"
32"	34"	15"	36"	18"	38"	21"	40"	24"
34"	36"	15"	38"	18"	40"	21"	42"	24"
36"	38"	15"	40"	18"	42"	21"	44"	24"
38"	40"	15"	42"	18"	44"	21"	46"	24"
40"	42"	15"	44"	18"	46"	21"	48"	24"
42"	44"	15"	46"	18"	48"	21"	~	~
44"	46"	15"	48"	18"	~	~	~	~
46"	48"	15"	~	~	~	~	~	~
48"	~	~	~	~	~	~	~	~

*Any size diameter change is possible.

**Call for height if not shown.

ABRUPT INCREASER

Part No. AI

The Abrupt Increaser is used to connect 2 sections of different diameters in a shorter space than a Tapered Increaser.

Includes 1 inner band of larger and smaller sizes and 1 seal ring.

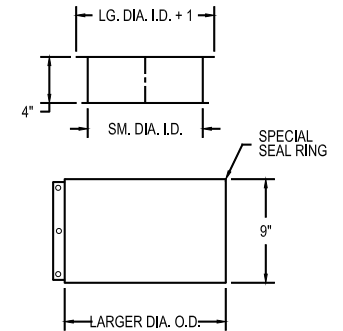

SYSTEM COMPONENTS

CUSTOM DIMENSIONS ARE AVAILABLE TO SUIT YOUR NEEDS IN EVEN AND ODD SIZES

90° TEE

Part No. 90T

The 90° Tee is used to join horizontal and vertical sections, as well as to provide for connection of drain or inspection fittings. Use either the Drain Tee Cap or the End Cap for closure of the unused opening.

Includes 2 inner bands and 2 outer bands.

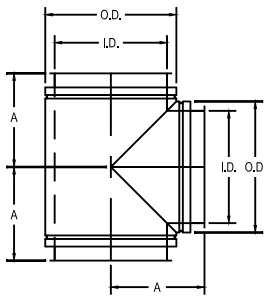

Part No. 90T	
I.D.	A
6"	7 ¹ / ₈ "
8"	8"
10"	9"
12"	10"
14"	11"
16"	12"
18"	13"
20"	14"
22"	15"
24"	16"
26"	17"
28"	18"
30"	19"
32"	20"
34"	21"
36"	22"
38"	23"
40"	24"
42"	25"
44"	26"
46"	27"
48"	28"

REDUCING 90° TEE

Part No. R90T

The Reducing 90° Tee is used to join horizontal and vertical sections of different sizes, as well as provide for connection to drain or inspection fittings. Use either the Drain Tee Cap or the End Cap for closure of the unused opening. Specify size of branch required.

Includes 1 each inner band and outer band for larger and smaller opening.

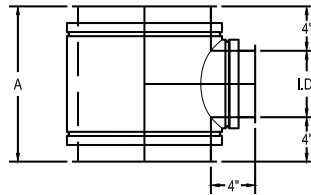

Part No. R90T	
I.D.	A
6"	14 ¹ / ₈ "
8"	16"
10"	18"
12"	20"
14"	22"
16"	24"
18"	26"
20"	28"
22"	30"
24"	32"
26"	34"
28"	36"
30"	38"
32"	40"
34"	42"
36"	44"
38"	46"
40"	48"
42"	50"
44"	52"
46"	54"

45° LATERAL TEE

Part No. 45LT

The 45° Lateral Tee is used for low flow resistance entry into a stack or breeching.

Includes 2 inner bands and 2 outer bands.

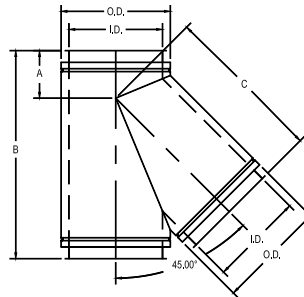

Part No. 45LT			
I.D.	A	B	C
6"	4 ⁷ / ₈ "	18 ³ / ₈ "	13 ¹ / ₂ "
8"	5 ¹ / ₄ "	21"	15 ³ / ₄ "
10"	5 ¹ / ₁₆ "	23 ⁷ / ₈ "	18 ³ / ₁₆ "
12"	6 ¹ / ₁₆ "	26 ¹ / ₁₆ "	20 ⁵ / ₁₆ "
14"	6 ¹ / ₂ "	29 ¹ / ₂ "	23"
16"	6 ⁵ / ₁₆ "	32 ⁵ / ₁₆ "	25 ⁵ / ₁₆ "
18"	7 ¹ / ₁₆ "	35 ³ / ₁₆ "	27 ³ / ₁₆ "
20"	7 ³ / ₄ "	38"	30 ¹ / ₄ "
22"	8 ³ / ₁₆ "	40 ¹ / ₁₆ "	32 ¹ / ₁₆ "
24"	8 ⁹ / ₁₆ "	43 ⁵ / ₁₆ "	35 ¹ / ₁₆ "
26"	9"	46 ¹ / ₂ "	37 ¹ / ₂ "
28"	9 ⁵ / ₁₆ "	49 ⁵ / ₁₆ "	39 ⁵ / ₁₆ "
30"	9 ¹ / ₁₆ "	52 ¹ / ₁₆ "	42 ⁵ / ₁₆ "
32"	10 ¹ / ₁₆ "	54 ¹ / ₁₆ "	44 ³ / ₁₆ "
34"	10 ⁵ / ₁₆ "	57 ¹ / ₁₆ "	47 ¹ / ₁₆ "
36"	11 ¹ / ₁₆ "	60 ⁵ / ₁₆ "	49 ⁵ / ₁₆ "
38"	11 ¹ / ₂ "	63 ³ / ₁₆ "	52"
40"	11 ⁷ / ₁₆ "	66 ¹ / ₁₆ "	54 ³ / ₁₆ "
42"	12 ⁵ / ₁₆ "	69 ⁵ / ₁₆ "	56 ³ / ₁₆ "
44"	12 ¹ / ₁₆ "	71 ¹ / ₁₆ "	59 ⁵ / ₁₆ "
46"	12 ³ / ₄ "	74 ³ / ₄ "	61 ⁵ / ₁₆ "
48"	13 ³ / ₁₆ "	77 ³ / ₁₆ "	64 ¹ / ₁₆ "

REDUCING 45° LATERAL TEE

Part No. R45LT

The Reducing 45° Lateral Tee is used for low flow resistance entry into a stack or breeching when the stack or breeching is a larger size. Specify size of branch required.

Includes 1 each inner band and outer band for larger and smaller opening.

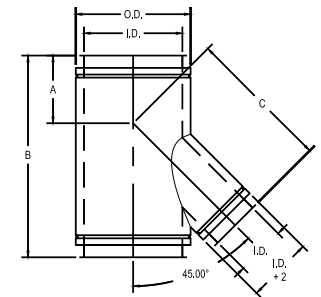

Part No. R45LT			
I.D.	A	B	C
6"	4 ¹ / ₁₆ "	16 ³ / ₁₆ "	12 ¹ / ₁₆ "
8"	3 ³ / ₈ "	18 ³ / ₁₆ "	14 ³ / ₄ "
10"	4 ¹ / ₄ "	21"	17 ⁷ / ₁₆ "
12"	4 ¹ / ₁₆ "	23 ⁷ / ₈ "	19 ⁹ / ₁₆ "
14"	5 ¹ / ₁₆ "	26 ¹ / ₁₆ "	22"
16"	5 ¹ / ₂ "	29 ¹ / ₂ "	24 ¹ / ₁₆ "
18"	5 ⁵ / ₁₆ "	32 ⁵ / ₁₆ "	26 ³ / ₁₆ "
20"	6 ⁵ / ₁₆ "	35 ³ / ₁₆ "	29 ¹ / ₄ "
22"	6 ³ / ₄ "	38"	31 ¹ / ₁₆ "
24"	7 ¹ / ₁₆ "	40 ¹ / ₁₆ "	34 ¹ / ₁₆ "
26"	7 ¹ / ₁₆ "	43 ⁵ / ₁₆ "	36 ¹ / ₂ "
28"	8"	46 ¹ / ₂ "	38 ⁷ / ₁₆ "
30"	8 ³ / ₁₆ "	49 ⁵ / ₁₆ "	41 ⁵ / ₁₆ "
32"	8 ³ / ₁₆ "	52 ¹ / ₁₆ "	43 ³ / ₁₆ "
34"	9 ¹ / ₁₆ "	54 ¹ / ₁₆ "	46 ¹ / ₁₆ "
36"	9 ⁵ / ₁₆ "	57 ¹ / ₁₆ "	48 ⁹ / ₁₆ "
38"	10 ¹ / ₁₆ "	60 ⁵ / ₁₆ "	51"
40"	10 ¹ / ₂ "	63 ³ / ₁₆ "	53 ³ / ₁₆ "
42"	10 ⁷ / ₈ "	66 ¹ / ₁₆ "	55 ³ / ₁₆ "
44"	11 ⁵ / ₁₆ "	69 ⁵ / ₁₆ "	58 ³ / ₁₆ "
46"	11 ¹ / ₁₆ "	71 ¹ / ₁₆ "	60 ⁵ / ₁₆ "
48"	12 ¹ / ₁₆ "	74 ³ / ₁₆ "	63 ³ / ₁₆ "

90° BOOT TEE

Part No. BT

The 90° Boot Tee is used to join horizontal and vertical sections with lower resistance as well as to provide for connection of drain or inspection fittings. Use either the Drain Tee Cap or the End Cap for closure of the unused opening.

Includes 2 inner bands and 2 outer bands.

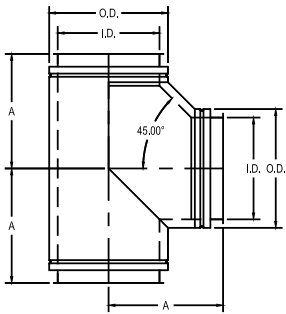

Part No. BT	
I.D.	A
6"	10½"
8"	11½"
10"	12½"
12"	13½"
14"	14½"
16"	15½"
18"	16½"
20"	17½"
22"	18½"
24"	19½"
26"	20½"
28"	21½"
30"	22½"
32"	23½"
34"	24½"
36"	25½"
38"	26½"
40"	27½"
42"	28½"
44"	29½"
46"	30½"
48"	31½"

90° WYE

Part No. 90Y

The 90° Wye is used for joining runs where low flow resistance is desired. All openings must be the same size. For connection to smaller diameter sections use the Tapered or Abrupt Increases.

Includes 2 inner bands and 2 outer bands.

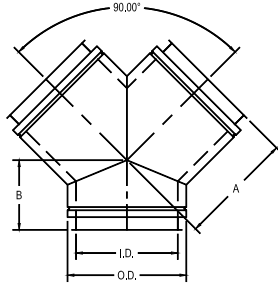

Part No. 90Y		
I.D.	A	B
6"	10½"	7"
8"	11½"	7½"
10"	12½"	7⅞"
12"	13½"	8½"
14"	14½"	8⅞"
16"	15½"	9⅞"
18"	16½"	9⅞"
20"	17½"	9⅞"
22"	18½"	10⅝"
24"	19½"	10⅝"
26"	20½"	11⅞"
28"	21½"	11⅞"
30"	22½"	11⅞"
32"	23½"	12⅞"
34"	24½"	12⅞"
36"	25½"	13⅞"
38"	26½"	13⅞"
40"	27½"	14⅞"
42"	28½"	14⅞"
44"	29½"	14⅞"
46"	30½"	15⅞"
48"	31½"	15⅞"

END CAP

Part No. EC

The End Cap is used to close an unused tee opening and to provide a means of accessing the interior of the system for inspection and cleaning.

Includes 1 inner band.

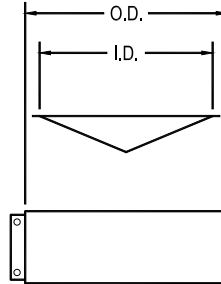

Part No. EC	
I.D.	O.D.
6"	8"
8"	10"
10"	12"
12"	14"
14"	16"
16"	18"
18"	20"
20"	22"
22"	24"
24"	26"
26"	28"
28"	30"
30"	32"
32"	34"
34"	36"
36"	38"
38"	40"
40"	42"
42"	44"
44"	46"
46"	48"
48"	50"

DRAIN TEE CAP

Part No. DTC

The Drain Tee Cap is used to close an unused tee opening and to provide a drain at the base of a vertical vent.

Includes 1 inner band.

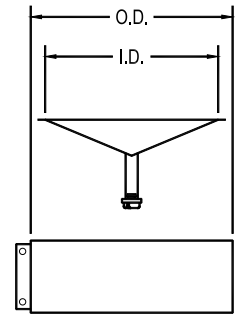

Part No. DTC	
I.D.	O.D.
6"	8"
8"	10"
10"	12"
12"	14"
14"	16"
16"	18"
18"	20"
20"	22"
22"	24"
24"	26"
26"	28"
28"	30"
30"	32"
32"	34"
34"	36"
36"	38"
38"	40"
40"	42"
42"	44"
44"	46"
46"	48"
48"	50"

SYSTEM COMPONENTS

CUSTOM DIMENSIONS ARE AVAILABLE TO SUIT YOUR NEEDS IN EVEN AND ODD SIZES

90° ELBOW

Part No. 90L

The 90° Elbow is used when making a 90° directional change. The 90° Elbow is available in sizes 6" through 24". For a 90° directional change in diameters from 26" through 48" use two 45° Elbows.

Includes 1 inner band and 1 outer band.

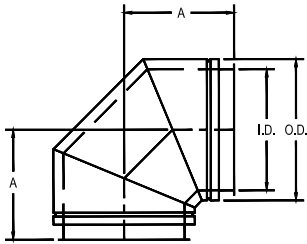

Part No. 90L

I.D.	A
6"	9 ¹ / ₁₆ "
8"	10 ⁷ / ₈ "
10"	11 ¹ / ₁₆ "
12"	12 ¹ / ₁₆ "
14"	13 ⁷ / ₈ "
16"	15 ¹ / ₁₆ "
18"	15 ¹ / ₁₆ "
20"	16 ⁷ / ₈ "
22"	17 ¹ / ₂ "
24"	18 ¹ / ₁₆ "



45° ELBOW

Part No. 45L

The 45° Elbow is used when a vertical or horizontal direction change of 45° is desired.

Includes 1 inner band and 1 outer band.

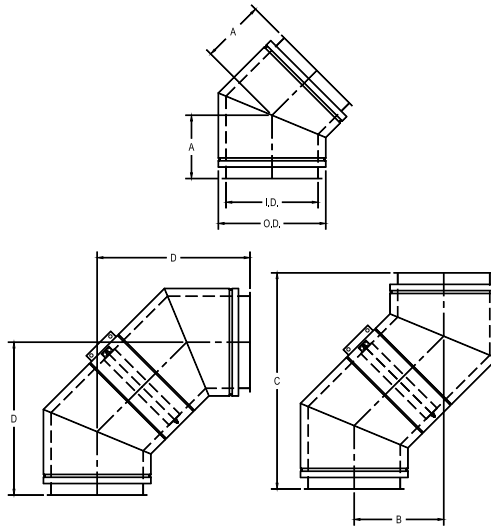

Part No. 45L

ID	A	B	C	D
6"	7"	9 ²⁹ / ₃₂ "	23 ²⁹ / ₃₂ "	16 ²⁹ / ₃₂ "
8"	7 ³ / ₈ "	10 ⁷ / ₁₆ "	25 ³ / ₁₆ "	17 ¹³ / ₁₆ "
10"	7 ³ / ₁₆ "	11 ³ / ₁₆ "	26 ³ / ₁₆ "	18 ⁵⁵ / ₆₄ "
12"	8 ¹ / ₈ "	11 ⁴³ / ₆₄ "	28 ¹¹ / ₆₄ "	19 ⁵⁹ / ₆₄ "
14"	8 ³ / ₈ "	12 ¹³ / ₆₄ "	29 ²⁹ / ₆₄ "	20 ⁵³ / ₆₄ "
16"	9 ¹ / ₁₆ "	1 ¹³ / ₁₆ "	30 ¹⁵ / ₁₆ "	21 ⁷ / ₈ "
18"	9 ¹ / ₂ "	13 ³ / ₁₆ "	32 ¹ / ₁₆ "	22 ¹⁵ / ₁₆ "
20"	9 ⁷ / ₈ "	13 ³¹ / ₃₂ "	33 ²⁷ / ₃₂ "	23 ²⁷ / ₃₂ "
22"	10 ³ / ₁₆ "	14 ³⁷ / ₆₄ "	35 ¹³ / ₆₄ "	24 ⁵⁷ / ₆₄ "
24"	10 ³ / ₄ "	15 ¹³ / ₆₄ "	36 ⁴⁵ / ₆₄ "	25 ⁶¹ / ₆₄ "
26"	11 ¹ / ₈ "	15 ⁴⁷ / ₆₄ "	37 ⁶³ / ₆₄ "	26 ⁵⁵ / ₆₄ "
28"	11 ⁹ / ₁₆ "	16 ²³ / ₆₄ "	39 ³¹ / ₆₄ "	27 ⁵⁹ / ₆₄ "
30"	11 ¹⁵ / ₁₆ "	16 ⁷ / ₈ "	40 ³ / ₄ "	28 ¹³ / ₁₆ "
32"	12 ³ / ₈ "	17 ¹ / ₂ "	42 ¹ / ₂ "	29 ⁷ / ₈ "
34"	12 ³ / ₄ "	18 ¹ / ₂ "	43 ¹⁷ / ₃₂ "	30 ²⁵ / ₃₂ "
36"	13 ³ / ₁₆ "	18 ²¹ / ₃₂ "	45 ¹ / ₃₂ "	31 ²⁷ / ₃₂ "
38"	13 ⁵ / ₈ "	19 ¹⁷ / ₆₄ "	46 ³³ / ₆₄ "	32 ⁵⁷ / ₆₄ "
40"	14"	19 ⁵¹ / ₆₄ "	47 ⁵¹ / ₆₄ "	33 ⁵¹ / ₆₄ "
42"	14 ⁷ / ₁₆ "	20 ²⁷ / ₆₄ "	49 ⁹ / ₆₄ "	34 ⁵⁵ / ₆₄ "
44"	14 ⁷ / ₈ "	21 ¹ / ₂ "	50 ²⁹ / ₃₂ "	35 ²⁹ / ₃₂ "
46"	15 ¹ / ₄ "	21 ¹ / ₁₆ "	52 ¹ / ₁₆ "	36 ¹³ / ₁₆ "
48"	15 ¹ / ₁₆ "	22 ³ / ₁₆ "	53 ³ / ₁₆ "	37 ⁷ / ₈ "

30° ELBOW

Part No. 30L

The 30° Elbow is used when a vertical or horizontal direction change of 30° is desired.

Includes 1 inner band and 1 outer band.

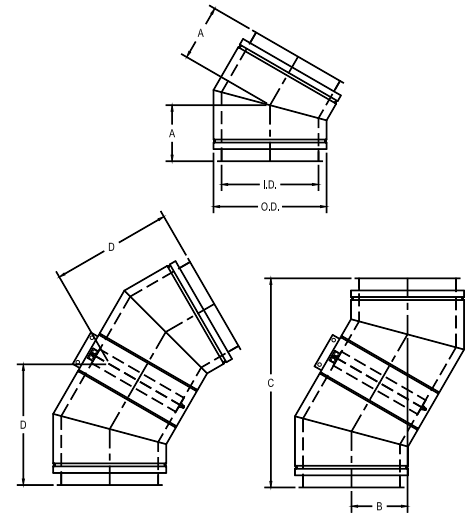

Part No. 30L

ID	A	B	C	D
6"	6 ¹ / ₈ "	6 ¹ / ₈ "	22 ⁵⁵ / ₆₄ "	13 ³ / ₁₆ "
8"	6 ³ / ₈ "	6 ³ / ₈ "	23 ⁵¹ / ₆₄ "	13 ³ / ₄ "
10"	6 ⁵ / ₈ "	6 ³ / ₈ "	24 ²³ / ₃₂ "	14 ⁹ / ₃₂ "
12"	6 ¹⁵ / ₁₆ "	6 ¹ / ₁₆ "	25 ⁵³ / ₆₄ "	14 ⁶¹ / ₆₄ "
14"	7 ³ / ₁₆ "	7 ¹ / ₁₆ "	26 ⁵³ / ₆₄ "	15 ³ / ₁₆ "
16"	7 ¹ / ₁₆ "	7 ¹ / ₁₆ "	27 ³ / ₄ "	16 ¹ / ₂ "
18"	7 ³ / ₄ "	7 ³ / ₄ "	28 ⁵⁹ / ₆₄ "	16 ⁶⁵ / ₆₄ "
20"	8"	8"	29 ⁵⁵ / ₆₄ "	17 ¹⁵ / ₆₄ "
22"	8 ³ / ₈ "	8 ¹ / ₄ "	30 ⁵¹ / ₆₄ "	17 ²³ / ₃₂ "
24"	8 ¹ / ₂ "	8 ¹ / ₂ "	31 ²³ / ₃₂ "	18 ¹ / ₁₆ "
26"	8 ³ / ₄ "	8 ³ / ₄ "	32 ²¹ / ₃₂ "	18 ⁵ / ₁₆ "
28"	9 ¹ / ₁₆ "	9 ¹ / ₁₆ "	33 ⁵³ / ₆₄ "	19 ¹ / ₃₂ "
30"	9 ¹ / ₁₆ "	9 ¹ / ₁₆ "	34 ³ / ₄ "	20 ¹ / ₁₆ "
32"	9 ¹ / ₈ "	9 ¹ / ₈ "	35 ¹ / ₁₆ "	20 ³⁹ / ₆₄ "
34"	9 ⁷ / ₁₆ "	9 ⁷ / ₁₆ "	36 ⁵ / ₁₆ "	21 ¹ / ₃₂ "
36"	10 ¹ / ₈ "	10 ¹ / ₈ "	37 ²⁵ / ₃₂ "	21 ¹ / ₁₆ "
38"	10 ³ / ₈ "	10 ³ / ₈ "	38 ²³ / ₃₂ "	22 ²³ / ₆₄ "
40"	10 ³ / ₈ "	10 ³ / ₈ "	39 ²¹ / ₃₂ "	22 ⁵¹ / ₆₄ "
42"	10 ¹⁵ / ₁₆ "	10 ¹ / ₁₆ "	40 ¹³ / ₁₆ "	23 ³ / ₁₆ "
44"	11 ¹ / ₁₆ "	11 ¹ / ₁₆ "	41 ³ / ₁₆ "	24 ⁷ / ₆₄ "
46"	11 ¹ / ₂ "	11 ¹ / ₂ "	42 ²⁹ / ₆₄ "	24 ²⁵ / ₃₂ "
48"	11 ³ / ₄ "	11 ³ / ₄ "	43 ⁵⁵ / ₆₄ "	25 ¹ / ₁₆ "

DRAIN SECTION

Part No. DS

The Drain Section is used to drain rain water and condensation from within the stack. The NPT nipple should be connected to a suitable drain.

Includes 1 inner band and 1 outer band.

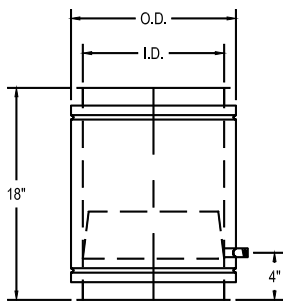

Part No. DS	
I.D.	O.D.
6"	8"
8"	10"
10"	12"
12"	14"
14"	16"
16"	18"
18"	20"
20"	22"
22"	24"
24"	26"
26"	28"
28"	30"
30"	32"
32"	34"
34"	36"
36"	38"
38"	40"
40"	42"
42"	44"
44"	46"
46"	48"
48"	50"

HORIZONTAL DRAIN

Part No. HD

The Horizontal Drain is used to attach grease traps and drain pipes to grease duct.

Includes 1 inner band and 1 outer band.

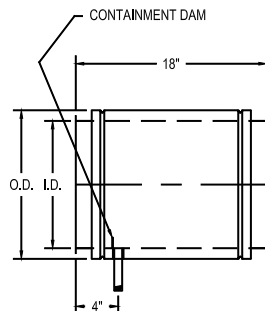

Part No. HD	
I.D.	O.D.
6"	8"
8"	10"
10"	12"
12"	14"
14"	16"
16"	18"
18"	20"
20"	22"
22"	24"
24"	26"
26"	28"
28"	30"
30"	32"
32"	34"
34"	36"
36"	38"
38"	40"
40"	42"
42"	44"
44"	46"
46"	48"
48"	50"

BASE DRAIN SECTION

Part No. BD

The Base Drain Section provides a bottom closure and drain attachment for base supported vents.

Includes 1 inner band and 1 outer band.

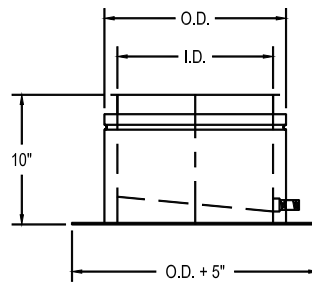

Part No. BD	
I.D.	O.D.
6"	8"
8"	10"
10"	12"
12"	14"
14"	16"
16"	18"
18"	20"
20"	22"
22"	24"
24"	26"
26"	28"
28"	30"
30"	32"
32"	34"
34"	36"
36"	38"
38"	40"
40"	42"
42"	44"
44"	46"
46"	48"
48"	50"

FAN ADAPTER

Part No. FA

The Fan Adapter is used to attach to an exhaust fan.

Includes 1 inner band and 1 outer band.

Note: Plenum boxes available for multiple fan systems.

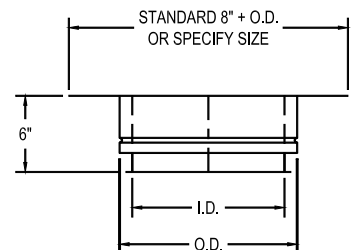

Part No. FA	
I.D.	O.D.
6"	8"
8"	10"
10"	12"
12"	14"
14"	16"
16"	18"
18"	20"
20"	22"
22"	24"
24"	26"
26"	28"
28"	30"
30"	32"
32"	34"
34"	36"
36"	38"
38"	40"
40"	42"
42"	44"
44"	46"
46"	48"
48"	50"

SYSTEM COMPONENTS

CUSTOM DIMENSIONS ARE AVAILABLE TO SUIT YOUR NEEDS IN EVEN AND ODD SIZES

FLASHING

Part No. FL

The Flashing is used in conjunction with the Rain Collar to seal roof penetrations. This part is designed for flat roofs. Custom Pitched Flashings are available upon request.

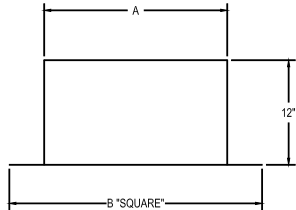

Part No. FL		
I.D.	A	B
6"	15 $\frac{1}{8}$ "	23 $\frac{1}{8}$ "
8"	17"	25"
10"	19"	27"
12"	21"	29"
14"	23"	31"
16"	25"	33"
18"	27"	35"
20"	29"	37"
22"	31"	39"
24"	33"	41"
26"	35"	43"
28"	37"	45"
30"	39"	47"
32"	41"	49"
34"	43"	51"
36"	45"	53"
38"	47"	55"
40"	49"	57"
42"	51"	59"
44"	53"	61"
46"	55"	63"
48"	57"	65"

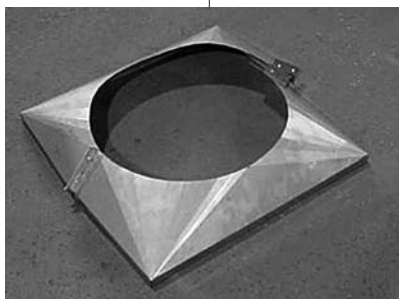

RAIN COLLAR

Part No. RC

The Rain Collar is used in conjunction with the Flashing to seal roof penetrations.

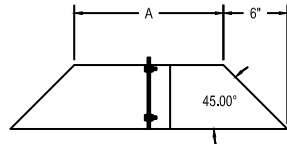

Part No. RC	
I.D.	A
6"	8 $\frac{3}{8}$ "
8"	10 $\frac{1}{8}$ "
10"	12 $\frac{1}{8}$ "
12"	14 $\frac{1}{8}$ "
14"	16 $\frac{1}{8}$ "
16"	18 $\frac{1}{8}$ "
18"	20 $\frac{1}{8}$ "
20"	22 $\frac{1}{8}$ "
22"	24 $\frac{1}{8}$ "
24"	26 $\frac{1}{8}$ "
26"	28 $\frac{1}{8}$ "
28"	30 $\frac{1}{8}$ "
30"	32 $\frac{1}{8}$ "
32"	34 $\frac{1}{8}$ "
34"	36 $\frac{1}{8}$ "
36"	38 $\frac{1}{8}$ "
38"	40 $\frac{1}{8}$ "
40"	42 $\frac{1}{8}$ "
42"	44 $\frac{1}{8}$ "
44"	46 $\frac{1}{8}$ "
46"	48 $\frac{1}{8}$ "
48"	50 $\frac{1}{8}$ "

INSULATED THIMBLE

Part No. IT

The Insulated Thimble is used when penetrating a combustible wall or roof. This part is designed for flat roofs. Custom Pitched Thimbles are available upon request.

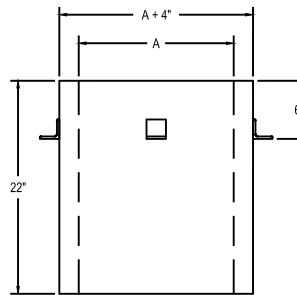

Part No. IT	
I.D.	A
6"	10"
8"	12"
10"	14"
12"	16"
14"	18"
16"	20"
18"	22"
20"	24"
22"	26"
24"	28"
26"	30"
28"	32"
30"	34"
32"	36"
34"	38"
36"	40"
38"	42"
40"	44"
42"	46"
44"	48"
46"	50"
48"	52"



RAIN CAP

Part No. CC

The Rain Cap is used at stack terminations to prevent water from entering the flue. A drain should be used at the base of stacks to drain off water that may be blown into flue.

Includes 1 inner band and 1 closure ring to seal outer shell joint.

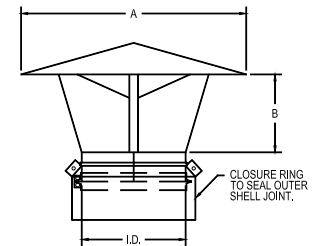

Part No. CC		
I.D.	A	B
6"	20"	4 $\frac{1}{2}$ "
8"	22"	6"
10"	24"	7 $\frac{1}{2}$ "
12"	26"	9"
14"	28"	10 $\frac{1}{2}$ "
16"	30"	12"
18"	32"	13 $\frac{1}{2}$ "
20"	34"	15"
22"	36"	16 $\frac{1}{2}$ "
24"	38"	18"
26"	40"	19 $\frac{1}{2}$ "
28"	42"	21"
30"	44"	22 $\frac{1}{2}$ "
32"	49"	24"
34"	52"	25 $\frac{1}{2}$ "
36"	55"	27"
38"	58"	28 $\frac{1}{2}$ "
40"	61"	30"
42"	64"	32 $\frac{1}{2}$ "
44"	67"	33"
46"	70"	34 $\frac{1}{2}$ "
48"	72"	36"

TOP SECTION

Part No. TS

The Top Section is used to protect the insulating space between the inner and outer shells when an open termination is required.

A drain should be used at the base of stacks to drain off water that enters the system.

Includes 1 inner band and shell joint.

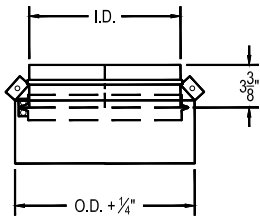

Part No. TS	
I.D.	O.D.
6"	8"
8"	10"
10"	12"
12"	14"
14"	16"
16"	18"
18"	20"
20"	22"
22"	24"
24"	26"
26"	28"
28"	30"
30"	32"
32"	34"
34"	36"
36"	38"
38"	40"
40"	42"
42"	44"
44"	46"
46"	48"
48"	50"

EXIT CONE

Part No. EXC

The Exit Cone is used to increase the flue gas velocity exiting the stack. A drain should be used at the base of stacks to remove any water that enters the stack.

Includes 1 inner band and 1 closure ring to seal outer shell joint.

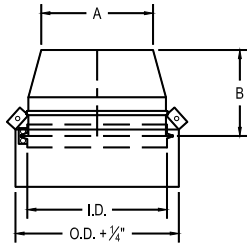

Part No. EXC		
I.D.	A	B
6"	4 7/8"	5 3/8"
8"	6 1/2"	6 7/8"
10"	8 1/8"	6 3/4"
12"	9 3/4"	7 1/2"
14"	11 3/8"	8 7/8"
16"	13 3/8"	8 7/8"
18"	14 3/4"	9 1/2"
20"	16 3/8"	10 1/4"
22"	18"	10 7/8"
24"	19 5/8"	11 5/8"
26"	21 1/4"	12 1/4"
28"	22 7/8"	13"
30"	24 1/2"	13 5/8"
32"	26 7/8"	14 3/8"
34"	27 3/4"	15"
36"	29 3/8"	15 3/4"
38"	31"	16 3/8"
40"	32 5/8"	17 1/8"
42"	34 1/4"	17 3/4"
44"	35 7/8"	18 1/2"
46"	37 1/2"	19 1/8"
48"	39 1/4"	19 3/4"

HORIZONTAL TERMINATION

Part No. HT

The Horizontal Termination is used when the stack terminates in a horizontal position. Birdscreen covers the opening to prevent any birds or rodents from entering.

Includes 1 inner band and 1 outer band.

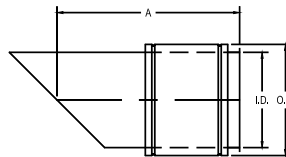

Part No. HT	
I.D.	A
6"	17"
8"	19"
10"	21"
12"	23"
14"	25"
16"	27"
18"	29"
20"	31"
22"	33"
24"	35"



SYSTEM COMPONENTS

CUSTOM DIMENSIONS ARE AVAILABLE TO SUIT YOUR NEEDS IN EVEN AND ODD SIZES

SUPPORT PLATE

Part No. SP

The Support Plate is the primary load carrying member of the vent assembly. This part is designed to support (B) (See Chart below) feet of vertical vent section as well as provide fixed points in breaching runs.

Includes 1 inner band and 2 half bands.

NOTE: THIS PART MUST BE PLACED AT THE CONNECTION OF TWO FLUE SECTIONS.

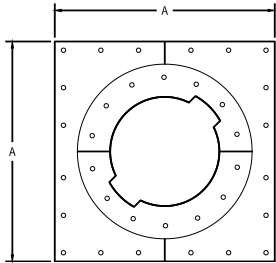

Part No. SP		
I.D.	A	B(FT.)
6"	19 ³ / ₁₆ "	306'
8"	21 ³ / ₁₆ "	269'
10"	23 ³ / ₁₆ "	255'
12"	25 ³ / ₁₆ "	237'
14"	27 ³ / ₁₆ "	227'
16"	29 ³ / ₁₆ "	213'
18"	31 ³ / ₁₆ "	201'
20"	34 ³ / ₁₆ "	192'
22"	36 ³ / ₁₆ "	180'
24"	38 ³ / ₁₆ "	172'
26"	40 ³ / ₁₆ "	161'
28"	42 ³ / ₁₆ "	151'
30"	44 ³ / ₁₆ "	142'
32"	46 ³ / ₁₆ "	161'
34"	48 ³ / ₁₆ "	151'
36"	50 ³ / ₁₆ "	113'
38"	52 ³ / ₁₆ "	101'
40"	54 ³ / ₁₆ "	93'
42"	56 ³ / ₁₆ "	85'
44"	58 ³ / ₁₆ "	76'
46"	60 ³ / ₁₆ "	68'
48"	62 ³ / ₁₆ "	60'

WALL SUPPORT

Part No. WS

The Wall Support is used to provide vent support along a wall. The Wall Support will maintain the required clearance to combustible structures when properly installed and can support (C) (See Chart Below) feet of vertical vent.

Includes 1 inner band and 2 half bands.

NOTE: THIS PART MUST BE PLACED AT THE CONNECTION OF TWO FLUE SECTIONS.

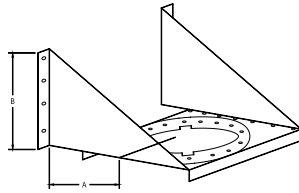

Part No. WS			
I.D.	A	B	C(FT.)
6"	11"	12 ³ / ₁₆ "	193'
8"	13"	14 ³ / ₁₆ "	171'
10"	14"	15 ³ / ₁₆ "	164'
12"	15"	17 ¹ / ₁₆ "	153'
14"	17"	19 ¹ / ₁₆ "	148'
16"	18"	20 ¹ / ₁₆ "	140'
18"	20"	22 ¹ / ₂ "	134'
20"	21"	24 ¹ / ₈ "	129'
22"	23"	26 ³ / ₁₆ "	123'
24"	24"	27 ¹ / ₂ "	119'
26"	26"	29 ¹ / ₂ "	113'
28"	27"	30 ¹ / ₈ "	108'
30"	29"	32 ¹ / ₈ "	103'
32"	30"	34 ¹ / ₄ "	120'
34"	32"	36 ¹ / ₄ "	114'
36"	33"	37 ⁵ / ₈ "	88'
38"	35"	39 ⁵ / ₁₆ "	81'
40"	36"	40 ¹⁵ / ₁₆ "	77'
42"	38"	42 ¹⁵ / ₁₆ "	73'
44"	39"	44 ⁵ / ₁₆ "	68'
46"	44"	47"	64'
48"	45"	49 ¹ / ₁₆ "	60'

GUY SECTION

Part No. GS

The Guy Section is to be used when the vent extends beyond the vertical limits above the roof line. The Guy Section should be connected to guy wires or a rigid guying structure.

Includes 1 inner band and 2 half bands.

NOTE: THIS PART MUST BE PLACED AT THE CONNECTION OF TWO FLUE SECTIONS.

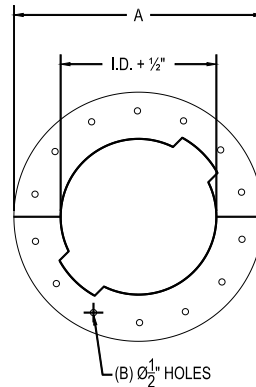

Part No. GS		
I.D.	A	B
6"	10 ⁵ / ₈ "	8
8"	12 ⁵ / ₈ "	8
10"	15 ³ / ₁₆ "	12
12"	17 ³ / ₁₆ "	12
14"	19 ³ / ₁₆ "	12
16"	21 ³ / ₁₆ "	12
18"	23 ³ / ₁₆ "	12
20"	25 ³ / ₁₆ "	12
22"	27 ³ / ₁₆ "	12
24"	30 ³ / ₁₆ "	12
26"	32 ³ / ₁₆ "	12
28"	34 ³ / ₁₆ "	16
30"	36 ³ / ₁₆ "	16
32"	38 ³ / ₁₆ "	16
34"	40 ³ / ₁₆ "	16
36"	42 ³ / ₁₆ "	20
38"	44 ³ / ₁₆ "	20
40"	46 ³ / ₁₆ "	20
42"	48 ³ / ₁₆ "	20
44"	50 ³ / ₁₆ "	24
46"	52 ³ / ₁₆ "	24
48"	54 ³ / ₁₆ "	28



FULL RING

Part No. FR

The Full Ring is used to guide horizontal and vertical runs. The part is simply bolted around the outer shell then rigidly connected to the building structure.

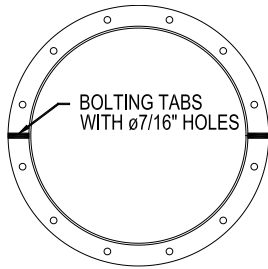

HALF RING

Part No. HR

The Half Ring has the same dimensions as the full ring. This Half Ring is used to support long horizontal runs. This part would be placed under the flue and then supported by rods connecting to the building structure.

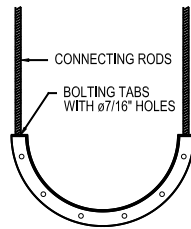

Part No. FR & HR

FLUE ID	RING ID	ANGLE SIZE	# HOLES	HOLE SIZE	B.C.
6"	8 ¹ / ₈ "	1 ¹ / ₄ " x 1 ¹ / ₄ " x 1 ¹ / ₈ "	8	3 ⁵ / ₈ "	9 ¹ / ₂ "
8"	10 ¹ / ₈ "	1 ¹ / ₄ " x 1 ¹ / ₄ " x 1 ¹ / ₈ "	8	3 ⁵ / ₈ "	11 ¹ / ₂ "
10"	12 ³ / ₁₆ "	1 ¹ / ₂ " x 1 ¹ / ₂ " x 1 ¹ / ₈ "	12	7 ¹ / ₁₆ "	13 ¹ / ₁₆ "
12"	14 ³ / ₁₆ "	1 ¹ / ₂ " x 1 ¹ / ₂ " x 1 ¹ / ₈ "	12	7 ¹ / ₁₆ "	15 ¹ / ₁₆ "
14"	16 ³ / ₁₆ "	1 ¹ / ₂ " x 1 ¹ / ₂ " x 3 ¹ / ₁₆ "	16	7 ¹ / ₁₆ "	18 ¹ / ₈ "
16"	18 ³ / ₁₆ "	1 ¹ / ₂ " x 1 ¹ / ₂ " x 3 ¹ / ₁₆ "	16	7 ¹ / ₁₆ "	20 ¹ / ₈ "
18"	20 ³ / ₁₆ "	1 ¹ / ₂ " x 1 ¹ / ₂ " x 3 ¹ / ₁₆ "	20	7 ¹ / ₁₆ "	22 ¹ / ₈ "
20"	22 ³ / ₁₆ "	1 ¹ / ₂ " x 1 ¹ / ₂ " x 3 ¹ / ₁₆ "	20	7 ¹ / ₁₆ "	24 ¹ / ₈ "
22"	24 ³ / ₁₆ "	1 ¹ / ₂ " x 1 ¹ / ₂ " x 3 ¹ / ₁₆ "	20	7 ¹ / ₁₆ "	26 ¹ / ₈ "
24"	26 ³ / ₁₆ "	2" x 2" x 3 ¹ / ₁₆ "	24	7 ¹ / ₁₆ "	28 ¹ / ₂ "
26"	28 ³ / ₁₆ "	2" x 2" x 3 ¹ / ₁₆ "	24	7 ¹ / ₁₆ "	30 ¹ / ₂ "
28"	30 ³ / ₁₆ "	2" x 2" x 3 ¹ / ₁₆ "	28	7 ¹ / ₁₆ "	32 ¹ / ₂ "
30"	32 ³ / ₁₆ "	2" x 2" x 3 ¹ / ₁₆ "	28	7 ¹ / ₁₆ "	34 ¹ / ₂ "
32"	34 ³ / ₁₆ "	2" x 2" x 3 ¹ / ₁₆ "	32	7 ¹ / ₁₆ "	36 ¹ / ₂ "
34"	36 ³ / ₁₆ "	2" x 2" x 3 ¹ / ₁₆ "	32	7 ¹ / ₁₆ "	38 ¹ / ₂ "
36"	38 ³ / ₁₆ "	2" x 2" x 3 ¹ / ₁₆ "	36	7 ¹ / ₁₆ "	40 ¹ / ₂ "
38"	40 ³ / ₁₆ "	2" x 2" x 3 ¹ / ₁₆ "	36	7 ¹ / ₁₆ "	42 ¹ / ₂ "
40"	42 ³ / ₁₆ "	2" x 2" x 3 ¹ / ₁₆ "	40	7 ¹ / ₁₆ "	44 ¹ / ₂ "
42"	44 ³ / ₁₆ "	2" x 2" x 3 ¹ / ₁₆ "	40	7 ¹ / ₁₆ "	46 ¹ / ₂ "
44"	46 ³ / ₁₆ "	2" x 2" x 3 ¹ / ₁₆ "	44	7 ¹ / ₁₆ "	48 ¹ / ₂ "
46"	48 ³ / ₁₆ "	2" x 2" x 3 ¹ / ₁₆ "	44	7 ¹ / ₁₆ "	50 ¹ / ₂ "
48"	50 ³ / ₁₆ "	2" x 2" x 3 ¹ / ₁₆ "	48	7 ¹ / ₁₆ "	52 ¹ / ₂ "

FLOOR/ROOF GUIDE

Part No. FRG

The Floor/Roof Guide is used at the penetration of floors and roofs to guide the vent. This part is designed to absorb lateral loads only. It will not support vertical vent sections.

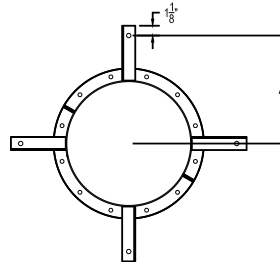

Part No. FRG

I.D.	A
6"	9 ³ / ₈ "
8"	10 ³ / ₈ "
10"	11 ³ / ₈ "
12"	12 ³ / ₈ "
14"	13 ³ / ₈ "
16"	14 ³ / ₈ "
18"	15 ³ / ₈ "
20"	16 ³ / ₈ "
22"	17 ³ / ₈ "
24"	18 ³ / ₈ "
26"	19 ³ / ₈ "
28"	20 ³ / ₈ "
30"	21 ³ / ₈ "
32"	22 ³ / ₈ "
34"	23 ³ / ₈ "
36"	24 ³ / ₈ "
38"	25 ³ / ₈ "
40"	26 ³ / ₈ "
42"	27 ³ / ₈ "
44"	28 ³ / ₈ "
46"	29 ³ / ₈ "
48"	30 ³ / ₈ "

WALL GUIDE

Part No. WG

The Wall Guide is used to guide long vertical runs that are placed adjacent to walls. This part will maintain proper clearance to combustibles when properly installed.

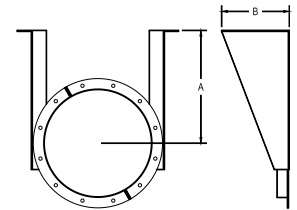

Part No. WG

I.D.	A	B
6"	11"	7 ¹ / ₁₆ "
8"	13"	8 ¹ / ₂ "
10"	14"	8 ⁵ / ₈ "
12"	15"	9"
14"	17"	9 ⁷ / ₁₆ "
16"	18"	9 ³ / ₄ "
18"	20"	10 ¹ / ₄ "
20"	21"	10 ⁹ / ₁₆ "
22"	23"	11 ¹ / ₈ "
24"	24"	11 ⁵ / ₁₆ "
26"	26"	11 ⁷ / ₈ "
28"	27"	12 ¹ / ₈ "
30"	29"	12 ¹ / ₁₆ "
32"	30"	12 ¹⁵ / ₁₆ "
34"	32"	13 ¹ / ₂ "
36"	33"	13 ¹ / ₁₆ "
38"	35"	14 ⁵ / ₁₆ "
40"	36"	14 ¹ / ₂ "
42"	38"	15 ¹ / ₁₆ "
44"	39"	15 ⁵ / ₁₆ "
46"	44"	16 ¹ / ₁₆ "
48"	45"	16 ³ / ₈ "

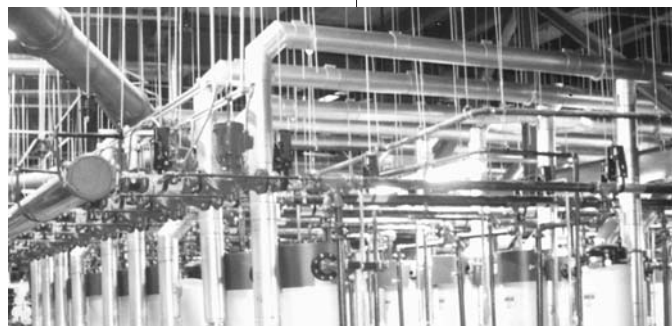

SYSTEM COMPONENTS

CUSTOM DIMENSIONS ARE AVAILABLE TO SUIT YOUR NEEDS IN EVEN AND ODD SIZES

eVent WEIGHT CHART

Part Description	Part Number	Inside Diameter (Inches)																					
		6"	8"	10"	12"	14"	16"	18"	20"	22"	24"	26"	28"	30"	32"	34"	36"	38"	40"	42"	44"	46"	48"
18" Straight Section	18s	18 lbs.	21	25	29	32	36	39	43	47	50	54	58	61	77	81	85	103	108	113	118	123	128
35" Straight Section	35S	26 lbs.	25	29	33	38	42	46	50	55	59	63	67	72	90	95	100	121	126	132	138	144	150
30 Degree Elbow	30L	8 lbs.	10	12	15	18	20	23	26	30	33	36	40	44	47	51	67	85	91	98	105	112	119
45 Degree Elbow	45L	9 lbs.	11	14	17	20	24	27	31	35	40	44	49	54	59	64	85	108	116	125	135	144	154
45 Degree Tee	45LT	18 lbs.	26	34	43	53	64	76	88	102	117	133	150	168	186	205	283	356	388	422	457	493	531
47" Straight Section	47S	23 lbs.	30	36	-	-	-	-	-	-	-	-	-	-	-	-	-	-	-	-	-	-	-
59" Straight Section	59S	-	38	47	-	-	-	-	-	-	-	-	-	-	-	-	-	-	-	-	-	-	-
90 Degree Elbow	90L	12 lbs.	17	23	30	38	46	55	65	76	88	-	-	-	-	-	-	-	-	-	-	-	-
90 Degree Tee	90T	15 lbs.	19	25	31	37	44	52	60	68	77	87	97	107	118	130	176	221	240	259	280	301	322
Abrupt Increaser	AI	7 lbs.	8	10	11	13	15	16	18	20	21	23	24	26	28	29	31	39	41	43	45	47	49
Base Drain	BD	12 lbs.	15	17	20	23	26	28	31	34	37	39	42	45	48	51	59	72	76	79	83	87	90
Boiler Kit Flanged	BKF	7 lbs.	8	10	11	13	15	16	18	20	21	23	24	26	28	29	31	39	41	43	45	47	49
Boiler Kits Raw	BKR	4 lbs.	5	6	7	8	8	9	10	11	12	13	14	15	15	16	17	25	26	27	29	30	31
Drain Section	DS	11 lbs.	14	17	20	23	26	29	32	35	37	40	43	46	49	52	66	83	87	91	95	99	103
Drain Tee Cap	DTC	5 lbs.	6	7	8	9	11	12	14	16	18	20	22	25	27	30	39	51	55	59	64	69	74
End Cap	EC	4 lbs.	5	6	7	8	10	11	13	15	17	19	21	24	26	29	38	50	54	58	63	68	73
Fan Adapter	FA	7 lbs.	8	10	11	13	15	16	18	20	21	23	24	26	28	29	31	39	41	43	45	47	49
Flashing	FL	11 lbs.	12	13	15	16	18	19	21	22	24	25	27	29	30	32	34	35	37	39	40	42	44
Floor/Roof Guide	FRG	10 lbs.	10	11	12	15	16	17	18	19	24	25	27	27	30	30	32	33	34	35	36	38	39
Full Ring	FR	3 lbs.	4	5	6	9	10	11	12	13	18	19	21	21	24	24	26	27	28	29	30	32	33
Guy Section	GS	9 lbs.	11	13	14	16	18	20	22	23	25	27	29	31	32	34	36	42	44	46	48	50	52
Half Ring	HR	2 lbs.	2	3	3	5	5	6	6	7	9	10	11	11	12	12	13	14	14	15	15	16	17
Horizontal Drain	HD	11 lbs.	14	17	20	23	26	29	32	35	37	40	43	46	49	52	66	83	87	91	95	99	103
Insulated Thimble	IT	20 lbs.	22	25	28	31	33	36	39	42	44	47	50	52	55	58	61	63	66	69	72	74	77
Nozzle Section	NS	11 lbs.	14	17	20	23	26	29	32	35	37	40	43	46	49	52	66	83	87	91	95	99	103
Rain Cap	CC	9 lbs.	11	13	16	18	21	24	27	31	34	37	41	45	52	57	65	73	79	86	92	99	105
Rain Collar	RC	4 lbs.	5	5	6	6	7	7	8	8	9	9	10	10	11	11	12	12	13	13	14	14	15
Support Plate	SP	31 lbs.	36	42	47	53	58	64	70	76	99	107	114	122	130	138	146	186	196	206	217	227	238
Tapered Increaser	TI	13 lbs.	16	20	23	27	30	33	37	40	44	47	50	54	57	61	78	97	102	106	111	116	121
Top Section	TS	3 lbs.	4	5	5	6	7	8	9	9	10	11	12	12	13	14	17	21	22	23	24	25	26
Variable Section	VS	23 lbs.	30	36	43	49	56	62	68	75	81	88	94	101	107	113	148	181	190	199	209	218	227
Wall Guide	WG	14 lbs.	17	19	21	26	28	31	34	37	44	48	50	53	57	60	62	66	69	73	75	85	87
Wall Support	WS	51 lbs.	61	73	84	97	108	124	138	156	186	206	222	244	262	285	304	360	381	416	439	477	501

All weights shown above are actual weights, for shipping weights multiply by 1.25

SAMPLE SPECIFICATION - eVent

The factory built modular vent shall be laboratory tested and listed in accordance with Underwriters Laboratories standard UL 1738 for use with category II, III, & IV appliances with a maximum flue gas temperature of 550°F, and ULC-S636-95 for gas vent - BH, Class I/Class II 245°C.

Vent sections shall be sealed with banded flanges and silicone joint sealant for temperatures up to 600°F with a UL tested pressure rating of 40" w.c.

Inner liner material shall be AL29-4C S/S. Inner shell thickness shall be .024" (24 ga. eVent) and .035" (20 ga. eVentPLUS) for 5" to 48" diameter systems. All inner liner seams shall be full penetrated welded. Riveted, tack or spot welded seams are not permitted.

Outer shell material shall be aluminized steel with a thickness of .034" for 5" to 48" diameter systems. Outer shell material of type 304, 430 or 316 stainless steel.

All outer shell seams shall be full penetration welded the entire length of the pipe section. Riveted, tack or spot welded seams are not permitted.

Between the inner and outer shells there shall be a minimum of a 1" air gap. Stainless steel centering clips shall be welded to the outer shell to maintain the 1" spacing and ensure concentricity of the shells.

Breeching and vent sections, when installed according to manufacturers instructions, shall comply with national safety standards and building codes. Stacks terminating above a roof must terminate as required by code or NFPA 211.

Vent sections exposed to atmospheric conditions shall be protected by a minimum of one base coat and one finish coat of heat resistant paint after installation. Outer shells of type 304, 430 or 316 stainless steel need not be painted.

NOTES

eVent STANDARD 5-YEAR WARRANTY

The Schebler eVent, where installed according to manufacturer's installation instructions, is warranted by the Schebler Company for a period of five (5) years from date of system start-up, against defects in material and workmanship of the product for parts only. Any defective part in the product will, at Schebler's option, either be repaired or replaced. Should the part be returned, the owner must pay all transportation charges. The repaired or replacement part will, in turn, be shipped by Schebler to the owner, freight prepaid. The warranty on any repaired or replacement part shall be for a duration of time no longer than the remaining or unexpired term of the original warranty.

This warranty does not cover labor or other service charges incurred by the owner, nor any parts not manufactured by The Schebler Company, or any other components that are not part of the eVent System.

This limited warranty is extended to the purchaser subject to the satisfaction of the following conditions:

- 1 *Generally accepted engineering practices have been followed to determine that sizing and material specifications are suitable for the application and environment involved.*
- 2 *The undamaged components have been correctly installed in accordance with the installation instructions published by The Schebler Company at the time of shipment.*

The Schebler Company assumes no liability for incidental or consequential damages of any kind or for any damages resulting in whole or part from misuse, improper installation, or inadequate maintenance of the system or component part thereof. This warranty is in lieu of all other express warranties or guarantees of any kind. All implied warranties, including merchantability and fitness, are limited to the duration of the express warranty contained herein. The Schebler Company neither assumes nor does it authorize any other person to assume on its behalf any other liability in connection with the sale of its products.

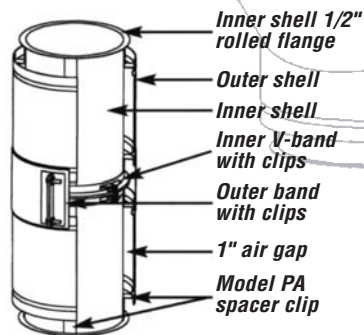

eVent EXTENDED 10-YEAR WARRANTY

The Schebler Company warrants owners of eVent against defects in material and workmanship in normal use for ten (10) years from the date of delivery to the construction site when installed, maintained and used as part of a Schebler eVent System and in accordance with The Schebler Company specifications. The Schebler Company further warrants any portion of the vent system repaired or replaced under this warranty for the remainder of the original warranty period.

This warranty is limited to repair or replacement of the product plus shipping cost to the failure location. This warranty does not cover any labor costs for removal or replacement of the defective product nor does this warranty cover any system components not furnished by The Schebler Company and installed as part of the system.

This limited warranty is extended to the purchaser subject to the satisfaction of the following conditions:

- 1 *System sizing and design has been performed by Schebler personnel and design parameters provided to The Schebler Company by the responsible engineer were and are accurately representative of the operating conditions.*
- 2 *The undamaged components have been correctly installed in accordance with system design and sizing as performed by Schebler and installation instructions published by The Schebler Company at the time of shipment.*
- 3 *Proper precautions have been taken to insure that appliance air is free of solvent or refrigerant vapors or any halogenated compound which may cause acid condensate to form within the vent.*
- 4 *The Schebler Company has supplied the entire vent or exhaust system from the appliance outlet to the termination of the stack.*
- 5 *Prior to start-up and thereafter, exposed aluminized steel surfaces are protected with a minimum of one base coat of primer and one finish coat of heat resistant paint at all times.*

The Schebler Company assumes no liability for incidental or consequential damages of any kind or for any damages resulting in whole or part from misuse, improper installation, or inadequate maintenance of the system or component part thereof. This warranty is in lieu of all other express warranties or guarantees of any kind. All implied warranties, including merchantability and fitness, are limited to the duration of the express warranty contained herein. The Schebler Company neither assumes nor does it authorize any other person to assume on its behalf any other liability in connection with the sale of its products.



5665 Fenno Road • P.O. Box 1008 • Bettendorf, Iowa 52722
Phone 563-359-0110 • Fax 563-359-8430
www.scheblerchimney.com